



# Engine Starting Systems



# It All Starts with Ingersoll Rand



Catalog pages with this symbol describe Ingersoll Rand products specified as "original equipment" by global engine manufacturers.

It's a tough world out there. Between competitive market demands, bottom-line concerns, and often brutal working conditions, you deal with your share of hassles. Keeping your equipment running shouldn't be one of them.

For over a half century, Ingersoll Rand has delivered the most reliable air starters for use in the world's most demanding industries and environments. With over 200 models, we have more installations in more applications around the world than any other manufacturer.

- *Leader in Air Starting*  
*broad line of turbine starters, vane starters and barring motors*
- *Best-in-class Performance*  
*horsepower, torque and efficiency*
- *Culture of Innovation*  
*latest technology and superior engineering*
- *Lab Tested, Field Proven*  
*rugged components ensure reliability in harsh conditions*
- *Global Support*  
*worldwide sales, service and engineering*

























We invite you to peruse our catalog, learn more about our wide range of products and discover for yourself why the biggest names in the business trust Ingersoll Rand air starters.



## Air Starter Industry Selection Guide

ENGINE STARTER SERIES						
	Locomotive	Marine	Off-Highway	Oil & Gas	Power Generation	Transportation

### TURBINE STARTERS

150T "F" Series						
ST400						
ST500						
ST600						
ST700/ST900						
ST1000/ST1000M						

### VANE STARTERS

SS100						
SS350						
150BM						
SS800						

### GAS TURBINE STARTERS

TS700/TS900/TS1400						
--------------------	--	--	--	---	---	--

### BARRING MOTORS

B006						
T480						

Category	Sub-Sections	Page #
<b>150BM Series</b>		<b>H1 - H6</b>
	<i>Features/Benefits</i>	H1
	<i>Dimensions</i>	H2
	<i>Performance Information/Model Coding</i>	H3
	<i>Replacement Kits/Parts</i>	H4
	<i>Parts and Accessories</i>	H5
	<i>Application Shots</i>	H6
<b>SS350 Series</b>		<b>I1 - I5</b>
	<i>Features/Benefits</i>	I1
	<i>Dimensions/ Model Coding</i>	I2
	<i>Performance Information/Application Shots</i>	I3
	<i>Replacement Kits/Parts</i>	I4
	<i>Parts and Accessories</i>	I5
<b>SS800 Series</b>		<b>J1 - J5</b>
	<i>Features/Benefits</i>	J1
	<i>Dimensions</i>	J2
	<i>Performance Information/Model Coding</i>	J3
	<i>Replacement Kits/Parts</i>	J4
	<i>Parts and Accessories/Application Shots</i>	J5
<b>Gas Turbine Starters</b>		<b>K1</b>
<b>TS700/TS900/TS1400 Series</b>		<b>K1 - K8</b>
	<i>Features/Benefits</i>	K1
	<i>Dimensions</i>	K2 - K5
	<i>Performance Information</i>	K6
	<i>Engine Selection Guide/Output Spline Data/Model Coding</i>	K7
	<i>Parts and Accessories/Replacement Kits</i>	K8
<b>Barring Motor Series</b>		<b>L1 - L2</b>
	<i>Features/Benefits</i>	L1
	<i>Performance Information/Parts and Accessories</i>	L2
<b>Accessories</b>		<b>M1 - M13</b>
	<i>Accessories Index</i>	M1
	<i>Relay Valves</i>	M2
	<i>Dimensions/Replacement Kits/Parts</i>	M3
	<i>Solenoid Control Valves</i>	M4
	<i>Dimensions</i>	M4 - M5
	<i>Push Button</i>	M6
	<i>Dimensions</i>	M6
	<i>Air Strainers</i>	M7
	<i>Dimensions</i>	M8
	<i>Mufflers</i>	M9
	<i>Dimensions</i>	M9
	<i>Regulators</i>	M10 - M11
	<i>In-Line Lubricators</i>	M12
	<i>Dimensions</i>	M13
<b>Installations</b>		<b>N1 - N6</b>
<b>IR Locations</b>		<b>Inside Back Cover</b>

Note: All dimensions shown are for reference only. Specifications subject to change without notice.

# High-Performance from Start to Finish

## Ingersoll Rand Turbine Starters



**Patented slip-fit, modular motor design** makes servicing simple and convenient.



From the remotest mines to the open seas, Ingersoll Rand turbine air starters withstand the toughest environmental and working conditions. Robust features and flexibility combine to deliver reliable, heavy-duty starting power for a wide range of industrial, oil and gas, marine, power generation, rail and mining applications.

Unlike cantilever designs, our fully-supported, high-speed rotors extend bearing life by minimizing deflection and ensuring concentric operation. Add in our lightweight, lube-free and field-serviceable motor design, and it's no wonder Ingersoll Rand turbine air starters are specified by premier engine OEMs across the globe.

- Lube-free turbine motor
- Easy field serviceability
- Robust gearing handles long crank cycles
- Fully-supported rotor for longer bearing life
- Sealed, oil-lubricated planetary sets (preferred worldwide for high-performance gear trains)
- Solid aluminum rotor design tames harsh, contaminated environments\*
- Modular motor design shares components with vane starters to reduce parts inventory
- Proven Ingersoll Rand front-end engagement system for greater reliability
- Class-leading power, durability and efficiency

\* ST1000 Series



**IR** Ingersoll Rand

## Turbine Motor Selection Guide (Lubrication Free)

For Diesel Engine Displacement (liters)	Catalog Section	Series	Gear Ratio	Extended Starting Capability (>10 sec.)	Max Power (HP)	Max Pressure (HP)	Air Consumption at Max HP SCFM (L/s)	Engagement Type**	Inlet Size (NPT)	Exhaust Size (NPT)	Gas Sealed
8 to 27	A	150TMG	F	Yes	28	150	710 (335)	Inertia	1 <sup>1</sup> / <sub>4</sub> "	2"	Yes
8 to 27	A	150TMP	F	Yes	28	150	710 (335)	Pre-Engaged	1 <sup>1</sup> / <sub>4</sub> "	2"	Yes
8 to 70	A	150TLP	F	Yes	28	90	780 (368)	Pre-Engaged	1 <sup>1</sup> / <sub>4</sub> "	2"	Yes
5 to 60	B	ST400	C	Yes	25	150	750 (354)	Pre-Engaged	1"	NA	No
5 to 60	B	ST455	C	Yes	23	120	780 (368)	Pre-Engaged	1"	NA	No
5 to 60	C	ST499	C	Yes	26	90	765 (361)	Pre-Engaged	1"	NA	No
5 to 100	C	ST599	F	Yes	44	150	1240 (585)	Pre-Engaged	1 <sup>1</sup> / <sub>4</sub> "	2"	Yes
5 to 100	D	ST544	F	Yes	28	150	710 (335)	Pre-Engaged	1 <sup>1</sup> / <sub>4</sub> "	2"	Yes
16 to 80	D	ST650	B	Yes	66	150	1450 (684)	Pre-Engaged	1 <sup>1</sup> / <sub>4</sub> "	5" V-Band Flange	No
16 to 80	D	ST699	B	Yes	67	90	1700 (802)	Pre-Engaged	1 <sup>1</sup> / <sub>2</sub> "	5" V-Band Flange	No
16 to 130	D	ST750/ ST950	B	No/Yes	55	150	1300 (614)	Inertia/ Pre-Engaged	1 <sup>1</sup> / <sub>2</sub> "	4" *	Yes
16 to 130	D	ST750/ ST999	B	No/Yes	66	90	1700 (802)	Inertia/ Pre-Engaged	1 <sup>1</sup> / <sub>2</sub> "	4" *	Yes
80 to 200	D	ST750/ ST950	C	No/Yes	55	150	1300 (614)	Pre-Engaged	1 <sup>1</sup> / <sub>2</sub> "	4" *	Yes
80 to 200	D	ST750/ ST999	C	No/Yes	66	90	1700 (802)	Pre-Engaged	1 <sup>1</sup> / <sub>2</sub> "	4" *	Yes
16 to 130	D	ST1060	B	Yes	70	150	1290 (609)	Inertia/ Pre-Engaged	1 <sup>1</sup> / <sub>2</sub> "	4" *	Yes
16 to 130	D	ST1099	B	Yes	68	90	1240 (585)	Inertia/ Pre-Engaged	1 <sup>1</sup> / <sub>2</sub> "	4" *	Yes
80 to 200	D	ST1060	C	Yes	70	150	1290 (609)	Pre-Engaged	1 <sup>1</sup> / <sub>2</sub> "	4" *	Yes
80 to 200	D	ST1099	C	Yes	68	90	1240 (585)	Pre-Engaged	1 <sup>1</sup> / <sub>2</sub> "	4" *	Yes
160 to 320	D	ST1060	D	Yes	70	150	1290 (609)	Pre-Engaged	1 <sup>1</sup> / <sub>2</sub> "	4" *	Yes
160 to 320	D	ST1099	D	Yes	68	90	1240 (585)	Pre-Engaged	1 <sup>1</sup> / <sub>2</sub> "	4" *	Yes
Gas Turbine Engines	I	TS700/ TS900	D	Yes	130	225	2200 (1038)	Permanently Engaged	1 <sup>1</sup> / <sub>2</sub> "	4" *	Yes

\* Or exhaust through a welded flanged 3<sup>1</sup>/<sub>2</sub>" schedule 40 pipe.

These figures are only a guide. For difficult-to-start engines or for operation under adverse conditions, use the next more powerful starter. For 2-stroke diesel engines, these figures may be multiplied by 1.5. Ex: a 150TMG could be used in a 41 liter 2-stroke diesel engine. For carbureted (gas) engines, these figures may be doubled. Ex: a 150BMP could be used on a 54 liter gasoline engine. Note 1 liter = 61.02 in<sup>3</sup>.

\*\* There are two basic types of air starters: pre-engaged and inertia. With pre-engaged starters, the drive pinion is completely engaged with the engine ring gear before the starter begins to crank the engine. With an inertia starter, the rotating drive pinion engages the engine ring gear simultaneously with the initial cranking of the engine.

## Air Starter Limited Warranty

Ingersoll Rand Company (“IR”) warrants to the original user its air starters (“Starter”) to be free of defects in material and workmanship for a period of one year from the date of purchase. IR will, at its option either (1) repair, without cost, any Starter found to be defective, including parts and labor charges, or (2) replace such Starter or refund the purchase price, less a reasonable allowance for depreciation, in exchange for the Starter. Repairs or replacements are warranted for the remainder of the original warranty.

If any Starter proves defective within its original one-year warranty period, it should be returned to any Authorized Starter Service Distributor, transportation prepaid with proof of purchase or warranty card. This warranty does not apply to Starters which IR has determined to have been misused or abused, improperly maintained by the user, or where the malfunction or defect can be attributed to the use of non-genuine IR repair parts.

IR MAKES NO OTHER WARRANTY, CONDITION OR REPRESENTATION OF ANY KIND WHATSOEVER, EXPRESSED OR IMPLIED, STATUTORY OR OTHERWISE, AND ALL IMPLIED WARRANTIES AND CONDITIONS RELATING TO MERCHANTABILITY AND FITNESS FOR A PARTICULAR PURPOSE ARE HEREBY DISCLAIMED. IR’s maximum liability is limited to the purchase price of the Starter and in no event shall IR be liable for any consequential, indirect incidental or special damages of any nature arising from the sale or use of the Starter, whether in contract, tort or otherwise.

**NOTE:** Some states do not allow limitations on incidental or consequential damages so that the above limitations may not apply to you. This warranty gives you specific legal rights and you may also have other rights which may vary from state to state.

## United States And International Certifications



**ABS**

ABS (American Bureau of Shipping)

ISO 9001:2000

Lloyd’s Register



Germanischer Lloyd ([www.germanlloyd.org](http://www.germanlloyd.org))

Korean Register of Shipping



Germanischer Lloyd



*Certificate information available upon request.*

# 150T™ “F” Series



**For engine displacement of:**  
Diesel—500 to 4300 CID (8 to 70 liters)  
Carbureted—1000 to 8600 CID  
(16 to 140 liters)



## Features/Benefits

- Efficient 36 hp turbine motor uses no external lubrication
- Same inlet and outlet locations as the 150BM Series starters for easy change-out
- Uses the proven front end of the 150BM starter
- Sealed, oil-lubricated planetary gears provide maintenance-free operation

## Versatile

- Sealed for use in gas and air applications
- Inertia and pre-engaged models
- Left- and right-hand rotation
- 4 inlet, 4 exhaust, and 16 drive housing orientations
- 30-150 psi (2.1-10.3 bars) operation

## Industry Applications:

MARINE



OIL & GAS



OFF-HIGHWAY



LOCOMOTIVE



TRANSPORTATION



POWER GENERATION





### Dimensions

**Weight:** 35 lbs (15.9 kg)

**Note:** All dimensions shown are for reference only. Specifications subject to change without notice.

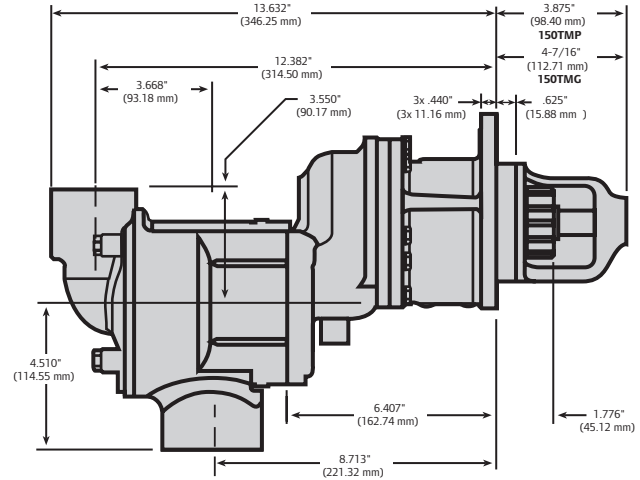
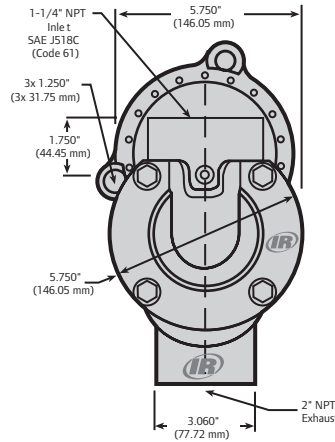

### Performance Information

Pressure PSI (bar)	Breakaway Torque ft-lb (Nm)	Speed @ Max HP RPM	Max Power HP (kw)	Flow @ Max HP SCFM (L/s)
<b>150TMFP/150TMGF – 44% ARC</b>				
60 (4.1)	74 (100)	1296	9 (7)	310 (146)
90 (6.2)	113 (153)	1480	16 (12)	430 (203)
120 (8.3)	147 (200)	1580	22 (17)	570 (269)
150 (10.3)	182 (247)	1620	28 (21)	710 (335)
<b>150TLPF – 99% ARC</b>				
30 (2.1)	72 (98)	1185	8 (6)	340 (160)
60 (4.1)	132 (179)	1500	19 (14)	580 (274)
90 (6.2)	206 (280)	1530	30 (23)	780 (368)
120 (8.3)	247 (336)	1540	36 (46)	1000 (475)

### Model Coding

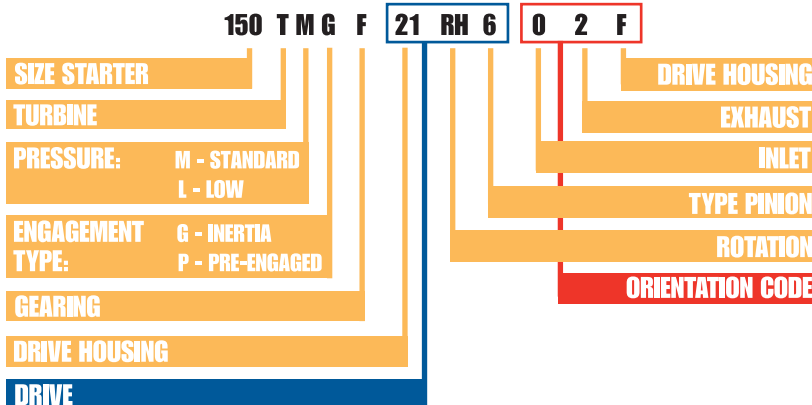

### Simple Crossover:

Current 150BM models are superseded to the 150™ "F" models by replacing the "B" with a "T" and the "E" with an "F".











*Example:* 150BMPE88R54 = 150TMFPF88R54

For low pressure applications (less than 90 psi or 6.2 bar) replace the "M" with an "L".

*Example:* 150TMPE88R54 = 150TLPF88R54

# 150 "F" Series

## Parts and Accessories

IR Part #	Description
 ST500-674 or 150T-312	2" Muffler
 150BMP-1051B	1/4" 12 V Solenoid Valve
 150BMP-2451B	1/4" 24 V Solenoid Valve
 SMB-G618	Gas Rated Push Button Valve
 SMB-618	Push Button Valve
 SRV125F	1-1/4" Relay/Solenoid Valve
 SRV125T	1-1/4" Relay Valve for Transit Aftermarket
 SRV125	1-1/4" Relay Valve for Stationary Air
 SRV150SS	1-1/2" Gas Rated Relay Valve
 150BMP-1058	Gladhand

IR Part #	Description
 150BMP-1064	1/8", 150 psi Pressure Gauge
 ST900-267-24	1-1/2" Strainer (300 Mesh)
 ST900-266-24	1-1/2" Strainer Element (300 Mesh)
 ST500-A735	2" Road Splash Deflector
 150BMP-1056	1/2" Check Valve
 150BMP-1067	1/2" Drain Valve
 ST500-K166	SAE J518 Split Flange

## Genuine Ingersoll Rand Replacement Kits

Tune Up Kit Part Number	Description
150TMP-TK1	150T Pre-engaged Starter Tune Up Kit
150TMG-TK1	150T Inertia Starter Tune Up Kit



150TMP-TK1 Parts

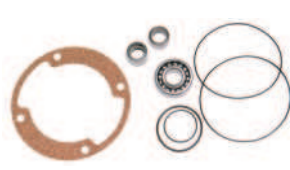

150TMG-TK1 Parts

## Motor Modules

Motor Module Part Number	Description
150TMFR-100	RH Half Arc Motor Module
150TMFL-100	LH Half Arc Motor Module
150TLFR-100	RH Half Arc Motor Module
150TLFL-100	LH Half Arc Motor Module

**Note:** The motor module can be used to convert an E ratio to an F ratio 150T starter and includes the motor and the gearing section.

# ST400 Series

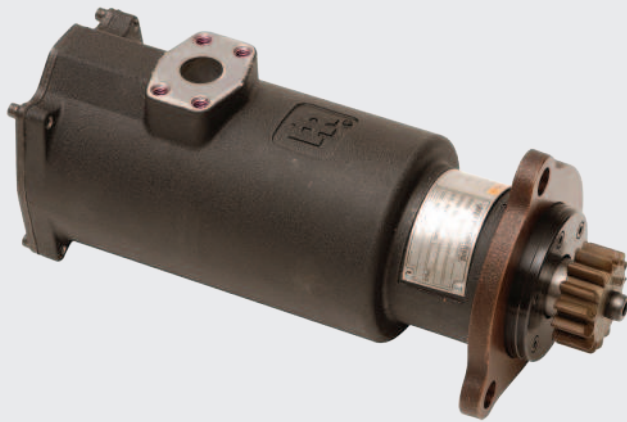

**For engine displacement of:**  
Diesel-300 to 3600 CID (5 to 60 liters)



## Features/Benefits

- Efficient 26 hp turbine motor uses no external lubrication
- One-hose hookup simplifies required piping
- In-line design weighs only 23 lbs (10.4 kg)
- Sealed oil-bath lubrication for gears and bearings provides maintenance free operation

## Versatile

- Removable mounting flange can be rotated 360 degrees for greater mounting flexibility
- Compact, lightweight design makes installation easy
- Overhung pinion design fits most worldwide manufacturers' engines
- 30-150 psi (2.1-10.3 bars) operation

## Industry Applications:

MARINE



POWER GENERATION



# ST400 Series

## Dimensions

**Weight:** 38 lbs (17.2 kg)

**Note:** All dimensions shown are for reference only. Specifications subject to change without notice.

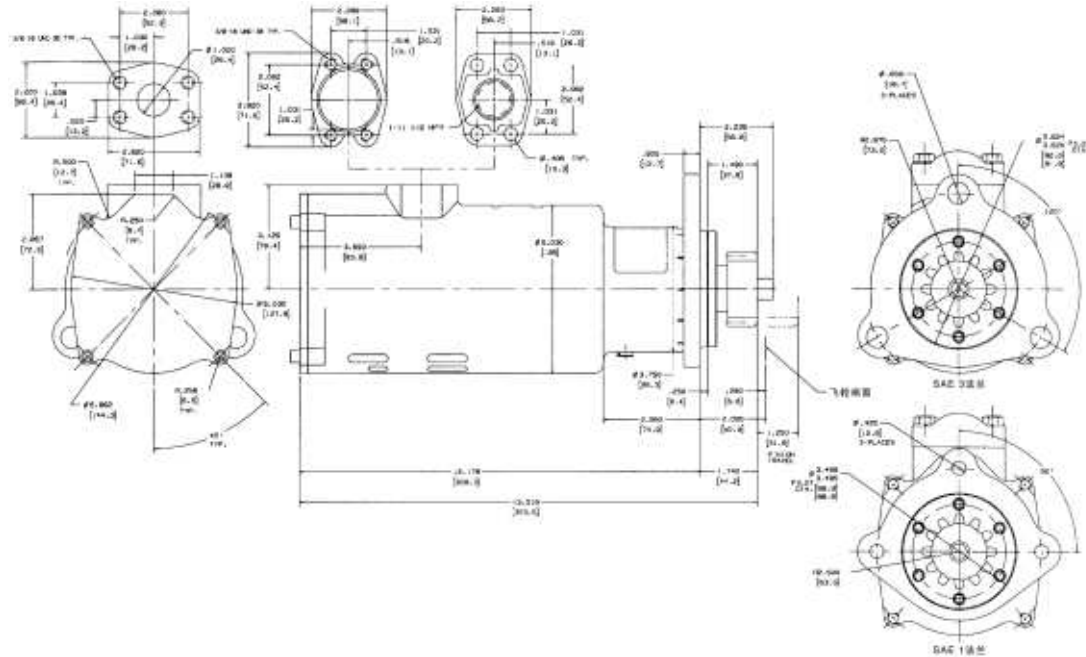

## Performance Information

Pressure PSI (bar)	Breakaway Torque ft-lb (Nm)	Speed @ Max HP RPM	Max Power HP (kw)	Flow @ Max HP SCFM (L/s)
<b>ST400 – 44% ARC</b>				
90 (6.2)	90 (122)	1500	14 (10)	430 (203)
120 (8.3)	120 (163)	1650	19 (14)	600 (284)
150 (10.3)	150 (203)	1650	25 (19)	750 (354)
<b>ST455 – 55% ARC</b>				
60 (4.1)	80 (109)	1400	10 (7)	23 (17)
90 (6.2)	135 (183)	1450	18 (13)	650 (307)
120 (8.3)	185 (251)	1500	23 (17)	780 (368)
<b>ST499 – 99% ARC</b>				
30 (2.1)	50 (68)	1550	7 (5)	320 (251)
60 (4.1)	115 (156)	1600	14 (10)	550 (260)
90 (6.2)	185 (251)	1650	26 (19)	765 (361)









An ST400C03L94 mounted on a MAN B&W 16/24 marine generator set.



An off-road application with an ST400IC01R72 on a Yituo engine.

## Parts and Accessories

	IR Part #	Description
	150BMP-1051B	1/4" 12 V Solenoid Valve
	150BMP-2451B	1/4" 24 V Solenoid Valve
	SMB-618	Push Button Valve
	SRV125F	1-1/4" Relay/Solenoid Valve
	SRV125T	1-1/4" Relay Valve for Transit Aftermarket
	SRV125	1-1/4" Relay Valve for Stationary Air
	SRV150	1-1/2" Relay Valve
	ST900-267-24	1-1/2" Strainer (300 Mesh)

	IR Part #	Description
	ST900-266-24	1-1/2" Strainer Element (300 Mesh)
	ST400-A339M	Manual Control Valve
	ST400-C339	Relay Valve with top-mounted Solenoid
	ST400-K17	1" NPT Flange Kit
	ST400-16	SAE J518 Split Flange

## Genuine Ingersoll Rand Replacement Kits

Tune Up Kit Part Number	Description
<b>Liner Assembly</b>	
ST400-A41R	Standard Arc Right Hand
ST400-A41L	Standard Arc Left Hand
ST455-A41R	55% Arc Right Hand
ST455-A41L	55% Arc Left Hand
ST499-A41R	Full Arc Right Hand
ST499-A41L	Full Arc Left Hand

**Parts**

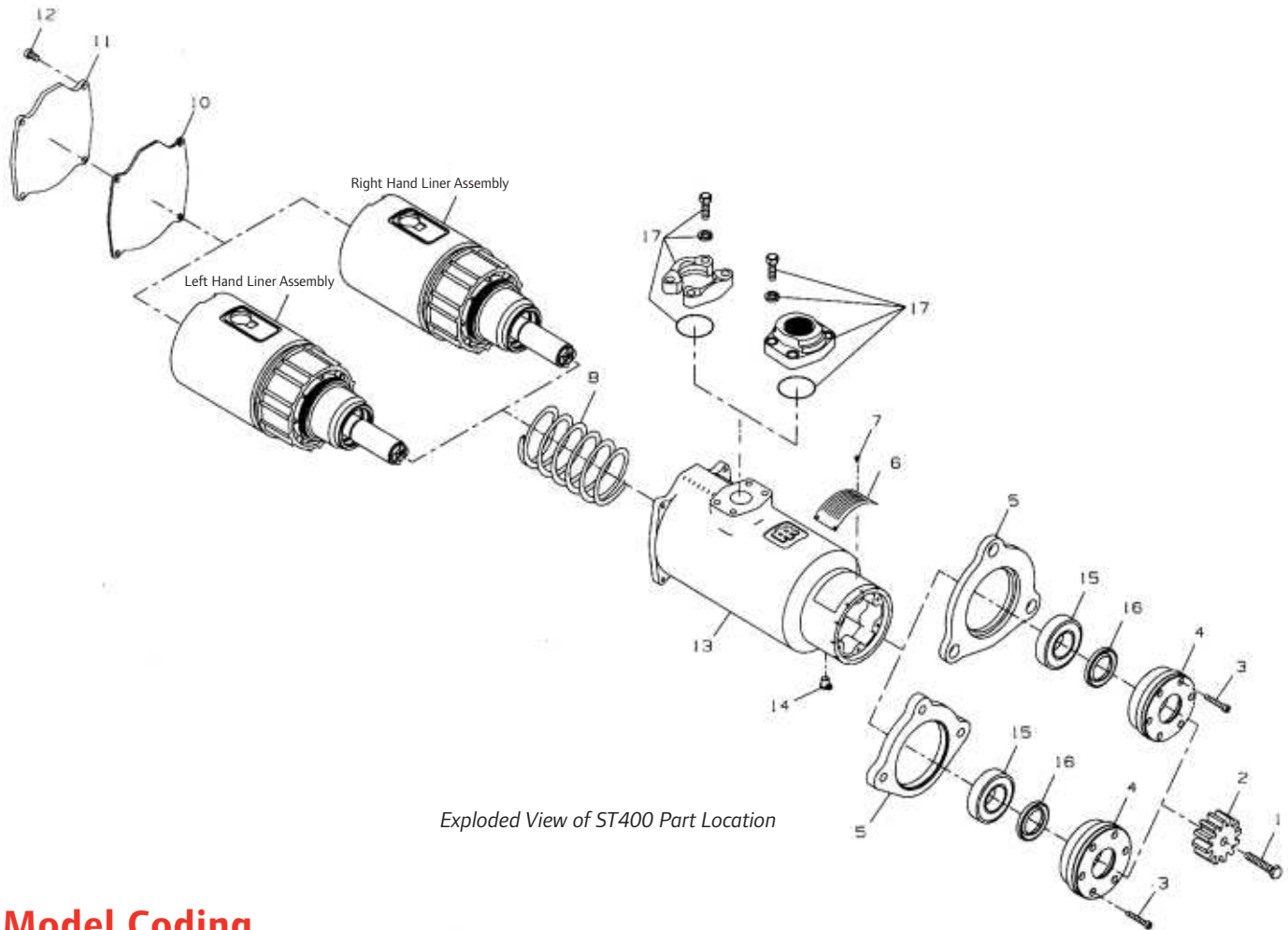

Exploded View of ST400 Part Location

**Model Coding**

**ST400 I C 03 R 31**

- ST400 - 44% ARC  
(Max. 150 PSI)**
- ST455 - 55% ARC  
(Max. 120 PSI)**
- ST499 - 99% ARC  
(Max. 90 PSI)**
- I - 1" NPT**
- NO LETTER - SAE SPLIT FLANGE**
- C - GEAR RATIO**

- PINION CODE**
- R - RIGHT HAND**
- L - LEFT HAND**
- 01 - SAE 1 FLANGE**
- 03 - SAE 3 FLANGE**

# ST500 Series

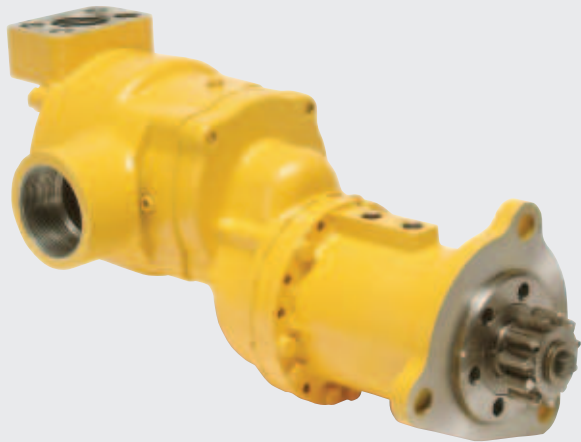

**For engine displacement of:**  
Diesel-500 to 6000 (8 to 100 liters)  
Carbureted-1000 to 12,000 CID  
(16 to 200 liters)



## Features/Benefits

- Powerful 44 hp turbine motor uses no external lubrication
- Steel insert at inlet ensures a solid connection
- Smooth pre-engagement piston minimizes ring gear wear
- Sealed, oil-lubricated planetary gears provide maintenance-free operation

## Versatile

- Sealed for use in gas and air applications
- For use with air or natural gas
- 4 inlet, 4 exhaust, and 16 drive housing orientations
- Left- or right-hand rotation
- Optional pinions and flanges to fit most engines
- 30-150 psi (2.1-10.3 bars) operation

## Industry Applications:

MARINE



OIL & GAS



OFF-HIGHWAY



POWER GENERATION



### Dimensions

**Weight:** 38 lbs (17.2 kg)

**Note:** All dimensions shown are for reference only. Specifications subject to change without notice.

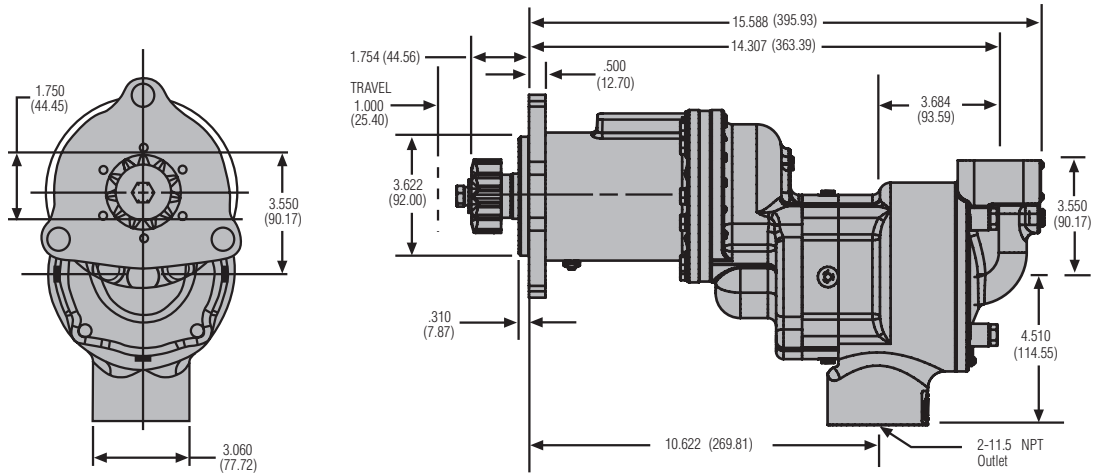

### Performance Information

Pressure PSI (bar)	Breakaway Torque ft-lb (Nm)	Speed @ Max HP RPM	Max Power HP (kw)	Flow @ Max HP SCFM (L/s)
<b>ST544</b>				
60 (4.1)	74 (100)	1296	9 (7)	310 (146)
90 (6.2)	113 (153)	1480	16 (12)	430 (203)
120 (8.3)	147 (200)	1580	22 (17)	600 (284)
150 (10.3)	182 (247)	1620	28 (21)	750 (354)
<b>ST599</b>				
30 (2.1)	72 (98)	1185	8 (6)	340 (160)
60 (4.1)	132 (179)	1500	19 (14)	580 (274)
90 (6.2)	206 (280)	1530	30 (23)	780 (368)
120 (8.3)	247 (336)	1540	36 (46)	1000 (475)
150 (10.3)	295 (400)	1560	44 (58)	1240 (585)





### Model Coding

**ST544 F 03 R 25 0 2 F J**





## Parts and Accessories

IR Part #	Description
 150BMP-1051B	1/4" 12 V Solenoid Valve
 SMB-G618	Gas Rated Push Button Valve
 SMB-618	Push Button Valve
 SRV125T SRV125	1-1/4" Relay Valve for Transit Aftermarket 1-1/4" Relay Valve for Stationary Air
 150BMP-1064	1/8", 150 psi Pressure Gauge
 ST500-A735	2" Road Splash Deflector

IR Part #	Description
 ST500-K166	SAE J518 Split Flange
 150BMP-1056	1/2" Check Valve
 150T-312	2" Muffler
 SMB-441	Liquid Sealant
 ST900-267-24	1-1/2" Strainer (300 Mesh)
 ST900-266-24	1-1/2" Strainer Element (300 Mesh)

## Genuine Ingersoll Rand Replacement Kits

Tune Up Kit Part Number	Description
ST500-TK1	ST500 Starter Tune Up Kit
ST500-SK1	ST500 Seal Kit

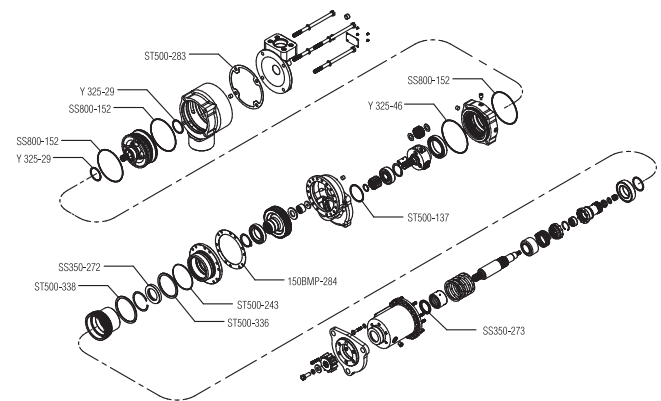
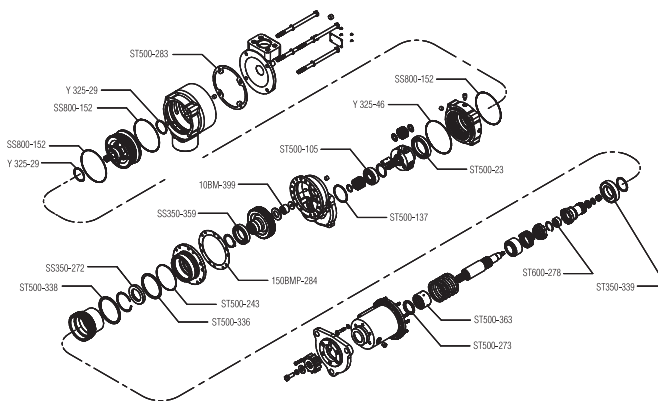

# ST600 Series



**For engine displacement of:**  
Diesel—1000 to 5000 CID (16 to 80 liters)  
Carbureted—2000 to 10,000 CID  
(32 to 160 liters)



## Features/Benefits

- Powerful 67 hp turbine motor uses no external lubrication
- Extended pilot for easier installation
- Offset pre-engaged ports for greater fitting positioning
- Smooth pre-engagement for limited ring gear wear
- 39 lb (17.7 kg) weight makes it the lightest starter in its class

## Versatile

- In-line design and lightweight make installation easy
- Left- or right-hand rotation
- 8 orientation options
- 30-150 psi (2.1-10.3 bars) operation
- For use with air only

## Industry Applications:

MARINE



OFF-HIGHWAY



POWER GENERATION



## Dimensions

**Weight:** 39 lbs (17.7 kg)

**Note:** All dimensions shown are for reference only. Specifications subject to change without notice.

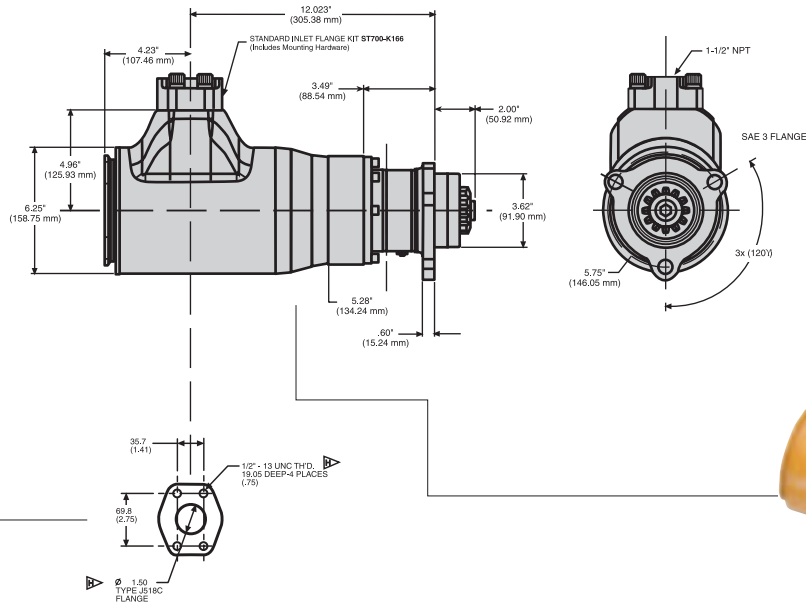

### Inlet Flange Kit (ST700-K166)

**Weight:** 4.5 lbs (2.0 kg)



## Performance Information

Pressure PSI (bar)	Breakaway Torque ft-lb (Nm)	Speed @ Max HP RPM	Max Power HP (kw)	Flow @ Max HP SCFM (L/s)
<b>ST650B</b>				
90 (6.2)	155 (210)	2300	34 (25)	850 (401)
120 (8.3)	225 (305)	2350	50 (37)	1150 (543)
150 (10.3)	260 (352)	2600	65 (49)	1450 (684)
<b>ST699B</b>				
30 (2.1)	110 (149)	1950	20 (15)	600 (283)
60 (4.1)	195 (264)	2200	41 (31)	1150 (543)
90 (6.2)	290 (393)	2400	67 (50)	1700 (802)

**Note:** Overtorque safety clutch set between 330 to 440 ft-lb (447 to 596 Nm)

## Model Coding

**ST6 50 B P 03 R 31**

TURBINE STARTER SERIES

PERCENT ARC

GEAR RATIO







PINION

ROTATION

SAE FLANGE

PRE-ENGAGED

### Parts and Accessories

IR Part #	Description
 150BMP-1051B	1/4" 12 V Solenoid Valve
 150BMP-2451B	1/4" 24 V Solenoid Valve
 SMB-G618	Gas Rated Push Button Valve
 SMB-618	Push Button Valve
 SRV150	1-1/2" Relay Valve
 150BMP-1058	Gladhand

IR Part #	Description
 150BMP-1064	1/8", 150 psi Pressure Gauge
 ST900-267-24	1-1/2" Strainer (300 Mesh)
 ST900-266-24	1-1/2" Strainer Element (300 Mesh)
 150BMP-1056	1/2" Check Valve
 150BMP-1067	1/2" Drain Valve

### Genuine Ingersoll Rand Replacement Kits

Tune Up Kit Part Number	Description
ST600-TK1	ST600 Starter Tune Up Kit
ST600-SK1	ST600 Starter Seal Kit

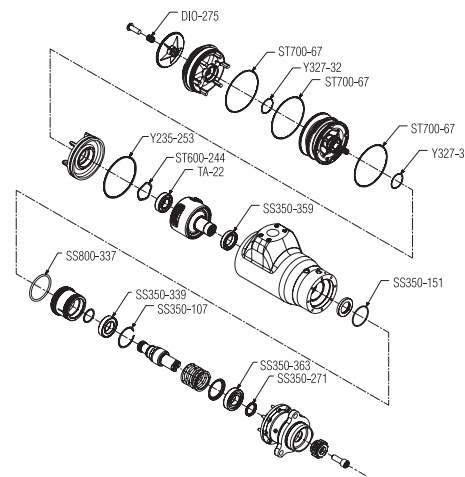

An ST650BP03R31 starter is shown being mounted on a CAT3512 used on a mine haul truck.

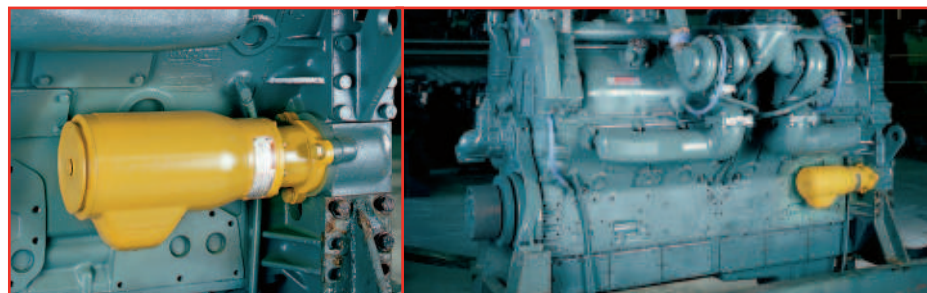

An ST650BP03R31 starter is shown mounted on a Detroit Diesel 12V-149R.

# ST700/900 Series



**For engine displacement of:**  
Diesel-1000 to 20,000 CID  
(16 to 320 liters)  
Carbureted-2000 to 40,000 CID  
(32 to 660 liters)



## Features/Benefits

- Powerful 66 hp turbine motor uses no external lubrication
- Robust gearing handles extended crank cycles
- B and C gearing options provide a broad range of starting torques
- Sealed, oil-lubricated planetary gears provide maintenance-free operation

## Versatile

- Sealed for use in gas and air applications
- Left- or right-hand rotation
- 4 inlet, 4 exhaust, and 16 housing orientations
- 30-150 psi (2.1-10.3 bars) operation
- Inertia and pre-engaged drives

## Industry Applications:

MARINE



OIL & GAS



OFF-HIGHWAY



LOCOMOTIVE



POWER GENERATION



## Dimensions

### ST750/ST799GBI & ST950/ST999BI Inertia

#### Weight:

ST750/ST799GBI 62 lbs (28.1 kg)  
 ST950/ST999BI 62 lbs (28.1 kg)

**Note:** All dimensions shown are for reference only. Specifications subject to change without notice.

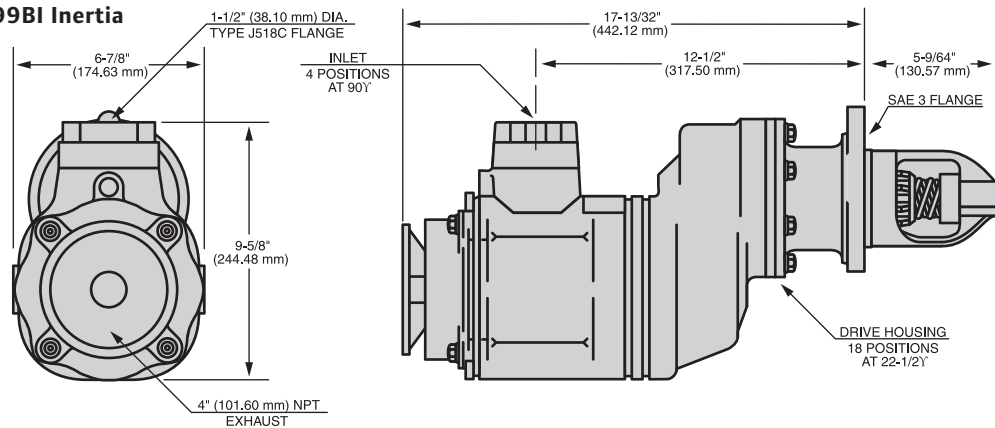

### ST750/ST799 & ST950/ST999 B & C Ratio Pre-engaged

#### Weight:

ST750/ST799GBPD 63 lbs (28.6 kg)  
 ST950/ST999BP 63 lbs (28.6 kg)

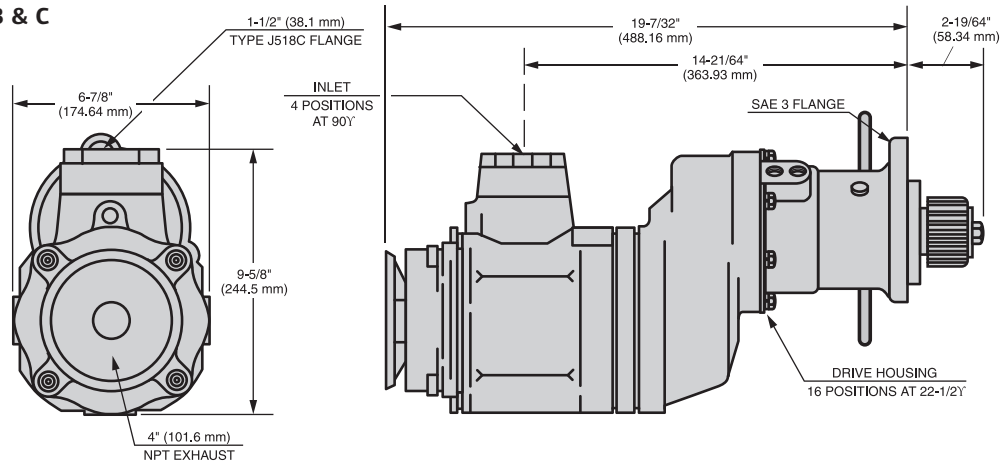

The ST999BP03R31 starter is ready for use on a Cat 3608 engine.

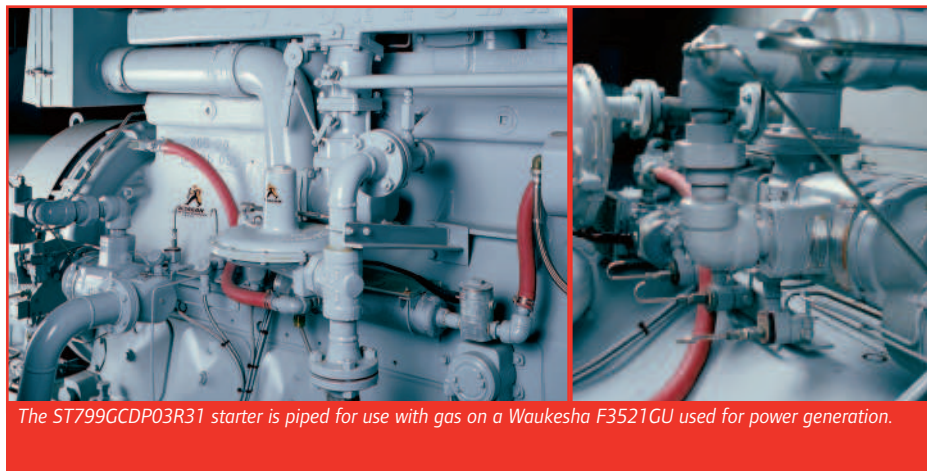

The ST799GCDP03R31 starter is piped for use with gas on a Waukesha F3521GU used for power generation.





## Performance Information

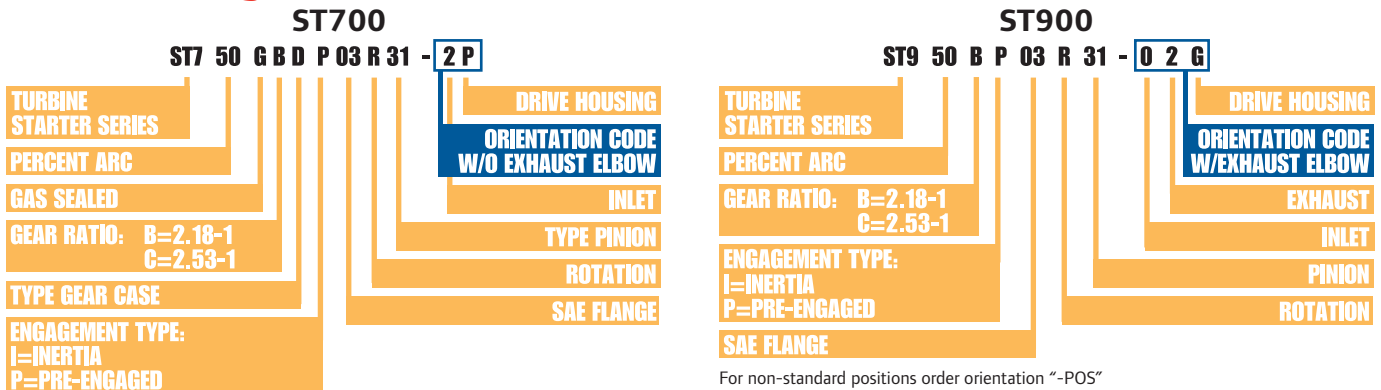

Pressure PSI (bar)	Breakaway Torque ft-lb (Nm)	Speed @ Max HP RPM	Max Power HP (kw)	Flow @ Max HP SCFM (L/s)
<b>ST750/ST950 B Ratio (Inertia &amp; Pre-engaged)</b>				
90 (6.2)	160 (217)	1950	30 (22)	850 (401)
120 (8.3)	225 (305)	2100	45 (34)	1100 (519)
150 (10.3)	250 (339)	2350	55 (41)	1300 (614)
<b>ST799/ST999 B (Inertia &amp; Pre-engaged)</b>				
30 (2.1)	110 (149)	1750	18 (13)	700 (330)
60 (4.1)	195 (264)	1950	36 (27)	1200 (566)
90 (6.2)	310 (420)	2250	66 (49)	1700 (802)
<b>ST750/ST950 C Ratio (Pre-engaged)</b>				
90 (6.2)	190 (257)	1675	30 (22)	850 (401)
120 (8.3)	260 (352)	1800	45 (34)	1100 (519)
150 (10.3)	285 (386)	2000	55 (41)	1300 (614)
<b>ST799/ST999 C Ratio (Pre-engaged)</b>				
30 (2.1)	130 (175)	1500	18 (13)	700 (330)
60 (4.1)	225 (305)	1630	36 (27)	1200 (566)
90 (6.2)	360 (485)	1935	66 (49)	1700 (802)

## Model Coding



## Parts and Accessories

	IR Part #	Description
	150BMP-1051B	1/4" 12 V Solenoid Valve
	150BMP-2451B	1/4" 24 V Solenoid Valve
	SMB-G618	Gas Rated Push Button Valve
	SMB-618	Push Button Valve
	SRV150	1-1/2" Relay Valve for Air
	SRV150SS	1-1/2" Gas Rated Relay Valve
	150BMP-1058	Gladhand

	IR Part #	Description
	150BMP-1064	1/8", 150 psi Pressure Gauge
	ST900-267-24	1-1/2" Strainer (300 Mesh)
	ST900-267-32	2" Strainer (300 Mesh)
	ST900-266-24	1-1/2" Strainer Element (300 Mesh)
	ST900-266-32	2" Strainer Element (300 Mesh)
	150BMP-1056	1/2" Check Valve
	150BMP-1067	1/2" Drain Valve

## Genuine Ingersoll Rand Replacement Kits

Tune Up Kit Part Number	Description
ST700-TK1	ST700 Starter Tune Up Kit
ST700I-TK6	ST700 Inertia Front End Tune Up Kit
ST700P-TK7	ST700 Pre-Engaged Front End Tune Up Kit
ST700D-TK8	ST700 and ST900 D Ratio Kit (4 O-Rings, 1 Retainer Ring)
ST750R-TK2	ST700-TK1 and ST750R-A53 Motor Assembly for RH ST750 Starters

Tune Up Kit Part Number	Description
ST750L-TK3	ST700-TK1 and ST750L-A53 motor assembly for LH ST750 starters
ST799R-TK4	ST700-TK1 and ST799R-A53 motor assembly for RH ST799 starters
ST799L-TK5	ST700-TK1 and ST799L-A53 motor assembly for LH ST799 starters
ST900-GK1	ST900 Gear Kit
ST900-SK1	ST900 Seal Kit



Parts

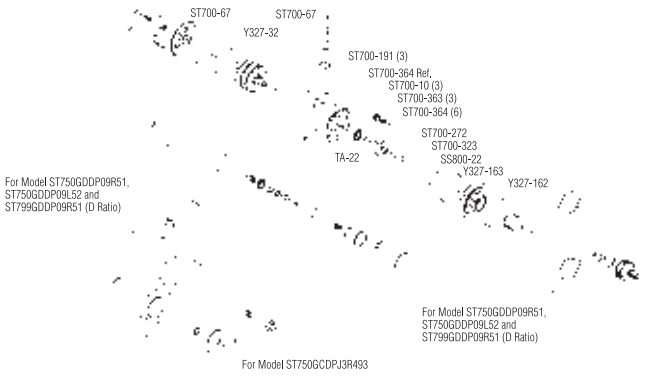

Exploded View of ST700-TK1 Part Location

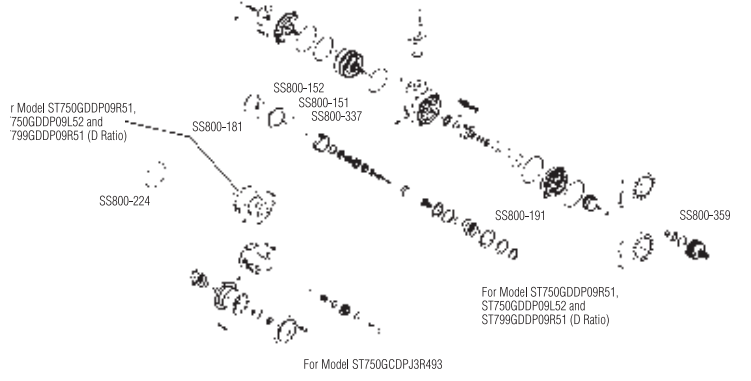

Exploded View of ST700P-TK7 Part Location

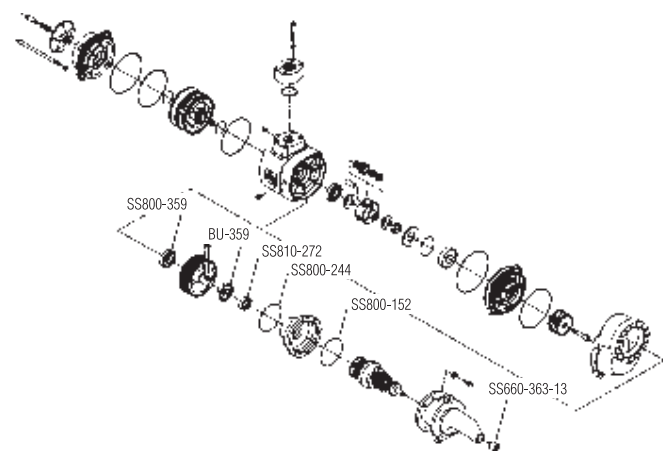

Exploded View of ST700I-TK6 Part Location

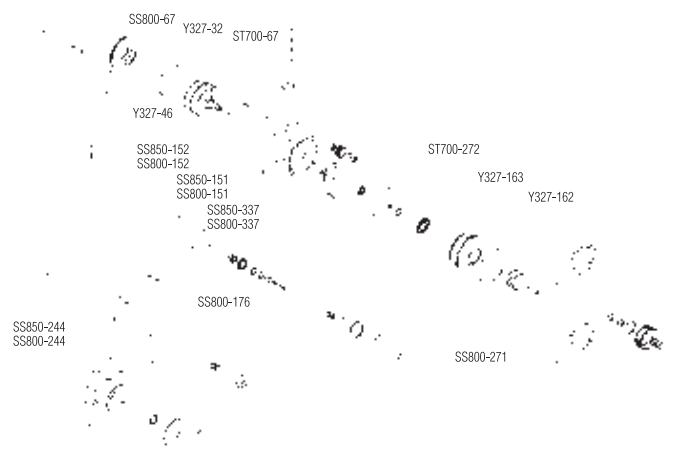

Exploded View of ST900-SK1 Part Location

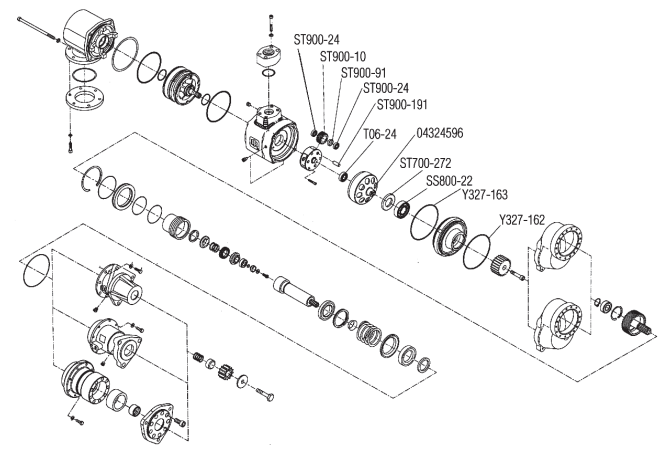

Exploded View of ST900-GK1 Part Location



ST700-TK1 Parts



ST700P-TK7 Parts

# ST1000/ST1000M Series

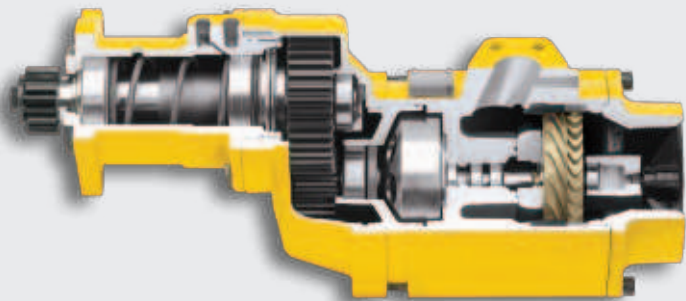

## For engine displacement of:

Diesel—1000 to 20,000 CID

(16 to 320 liters)

Carbureted—2000 to 40,000 CID

(32 to 660 liters)



## Features/Benefits

- Powerful 70 hp turbine motor uses no external lubrication and offers best in class efficiency
- Patented, solid aluminum motor design enables reliable operation in harsh, contaminated environments
- Robust gearing handles extended crank cycles
- Patented, fully-supported high-speed rotor extends bearing life by minimizing deflection and ensuring concentric running; a better alternative to cantilever designs

## Versatile

- Sealed for use in gas and air applications
- Left- or right-hand rotation available
- 4 inlet, 4 exhaust, and 16 housing orientations
- 30-150 psi (2.1-10.3 bars) operation
- Inertia and pre-engaged drives available
- Patented slip-fit motor design makes servicing simple and convenient
- ST1000M version with 2-inch NPT inlet reduces the need for piping changes on some competitive models

## Industry Applications:

MARINE



OIL & GAS



OFF-HIGHWAY



LOCOMOTIVE



POWER GENERATION



## Dimensions

### Pre-Engaged B & C Ratio Weight: 76 lbs (34.5 kg)

**Note:** All dimensions shown are for reference only. Specifications subject to change without notice.

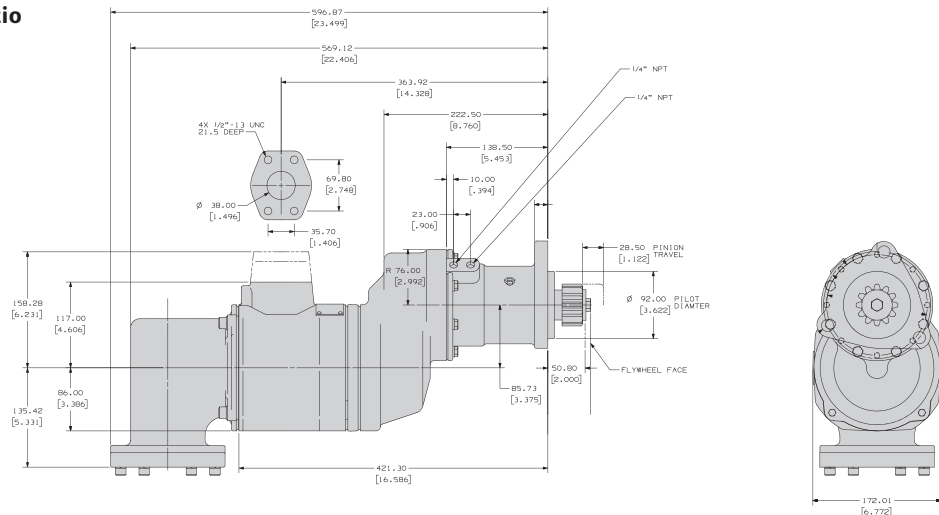

### ST1000M Weight: 76 lbs (34.5 kg)

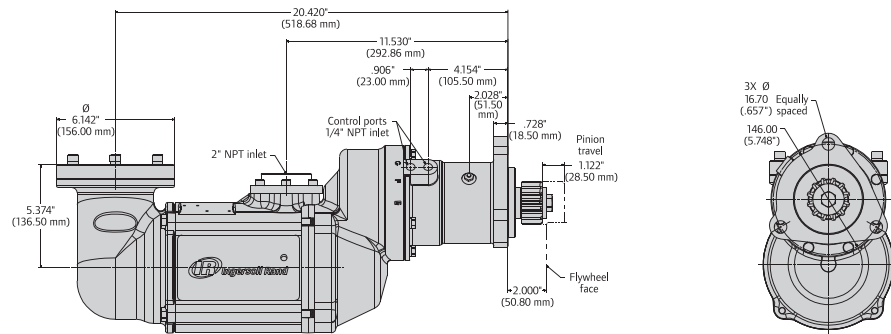

### Pre-Engaged D Ratio Weight: 102 lbs (46.3 kg)

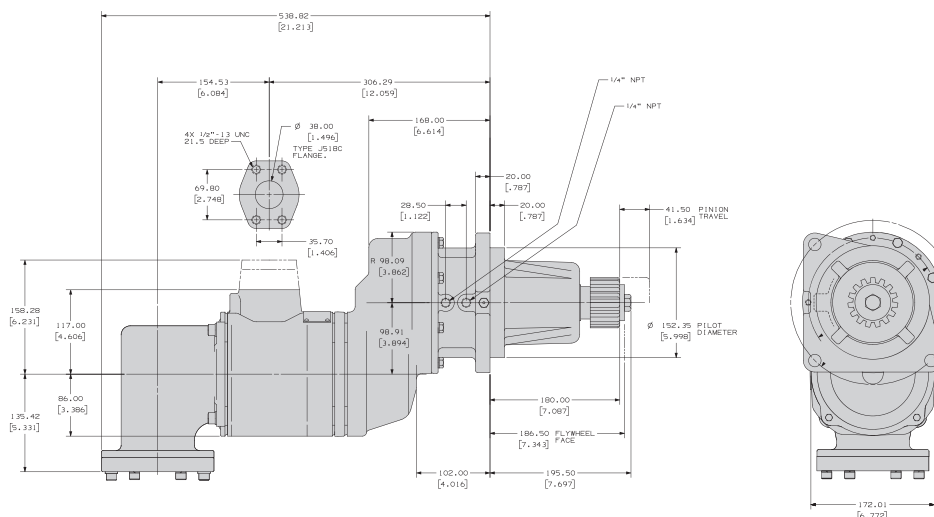

## Performance Information

Pressure PSI (bar)	Breakaway Torque ft-lb (Nm)	Speed @ Max HP RPM	Max Power HP (kw)	Flow @ Max HP SCFM (L/s)
<b>ST1060 B Ratio</b>				
30 (2)	53 (71)	1175	7 (5)	370 (175)
60 (4)	115 (156)	1550	20 (15)	590 (278)
90 (6)	220 (298)	1780	39 (29)	820 (387)
120 (8)	295 (400)	1900	53 (39)	1050 (496)
150 (10)	353 (478)	2050	70 (52)	1290 (609)
<b>ST1099 B Ratio</b>				
30 (2)	82 (111)	1425	13 (10)	540 (255)
60 (4)	200 (271)	1850	36 (27)	890 (420)
90 (6)	347 (470)	2060	68 (51)	1240 (585)
<b>ST1060 C Ratio</b>				
30 (2)	62 (84)	1025	7 (5)	370 (175)
60 (4)	143 (194)	1350	20 (15)	590 (278)
90 (6)	256 (347)	1515	39 (29)	820 (387)
120 (8)	342 (463)	1675	53 (39)	1050 (496)
150 (10)	409 (554)	1780	70 (52)	1290 (609)
<b>ST1099 C Ratio</b>				
30 (2)	98 (133)	1225	13 (10)	540 (255)
60 (4)	234 (317)	1580	36 (27)	890 (420)
90 (6)	400 (542)	1770	68 (51)	1240 (585)
<b>ST1060 D Ratio</b>				
30 (2)	85 (115)	765	7 (5)	370 (175)
60 (4)	195 (264)	985	20 (15)	590 (278)
90 (6)	326 (442)	1125	39 (29)	820 (387)
120 (8)	462 (626)	1205	53 (39)	1050 (496)
150 (10)	557 (755)	1650	70 (52)	1290 (609)
<b>ST1099 D Ratio</b>				
30 (2)	132 (179)	900	13 (10)	540 (255)
60 (4)	318 (431)	1170	36 (27)	890 (420)
90 (6)	540 (732)	1300	68 (51)	1240 (585)

## Genuine Ingersoll Rand Replacement Kits

Tune Up Kit Part Number	Description
ST700P-TK7	Pre-engaged Tune Up Kit
ST700I-TK6	Inertia Tune Up Kit
ST700D-TK8	D Ratio Tune Up Kit
ST1000-SK1	Seal Kit
ST1000-GK1	Planetary Gear Kit
ST1000R-K53-37	Rotor Replacement Kit (RH)

Tune Up Kit Part Number	Description
ST1000L-K53-37	Rotor Replacement Kit (LH)
ST1000-K24	Rotor Bearing Kit
ST1000R-K212	Motor Adapter Kit (RH)
ST1000L-K212	Motor Adapter Kit (LH)
ST1000K-562	Straight Exhaust Kit
ST1000K-350	Elbow Exhaust Kit



ST700P-TK7 Parts



ST1000-SK1 Parts

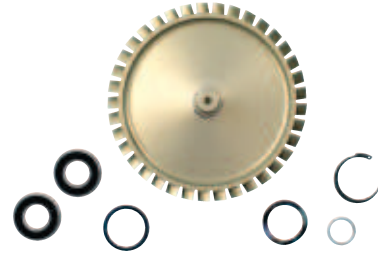



ST1000R-K53-37 and ST1000L-K53-37 Parts



ST1000K-350 Part

## Parts and Accessories

IR Part #	Description
 ST700-K166	Inlet Flange Kit
 ST700-K351	Exhaust Flange Kit
 SRV150	1-1/2" Relay Valve for Air
 SRV150SS	1-1/2" Gas Rated Stainless Steel Relay Valve
 ST1000-267-24	1-1/2" Stainless Steel Y Strainer
 ST1000-267-32	2" Stainless Steel Y Strainer

IR Part #	Description
 SMB-618	Push Button Valve
 SMB-G618	Gas Rated Push Button Valve
38600714 (RR152-F30)	1.5" 90 Degree
38754917 (RR152-F30-14)	High Pressure Regulator Relay Valve (for use with air only)
16675845 (RR250-F30)	2.5" In-line



*The ST1000 won't clog up with particles or debris, and an integral slip clutch that eliminates shock-loading and provides better long-term protection. We use a proprietary wear-resistant coating to deliver outstanding resistance to environmental contamination.*



*The ST1099CP03R25 is piped for use on a Waukesha 7044 gas compression package.*



*An ST1060CP03R25S on an EMD 16-645 genset application.*

# Superior Engineering, Legendary Performance

*Ingersoll Rand Vane Starters*



With their simple, rugged design, easy maintenance, and legendary durability, Ingersoll Rand vane starters reign as the most commonly used air starters in the world. Our vane motors develop maximum horsepower at speeds as low as 5000 RPM plus require only a small amount of lubrication for maximum life. This ability to thrive at lower speeds improves each motor's bearing life, minimizes planetary gear reduction and delivers more torque per pound than other displacement motors.

- High torque, lower RPMs
- Easy field serviceability
- Modular design shares components with turbine starters

Reliability and high-efficiency at a low cost have made our 150 BM and SS800 models the benchmark starters in their class.



## Vane Motor Selection Guide

For Diesel Engine Displacement (liters)	Catalog Section	Series	Gear Ratio	Extended Starting Capability (>10 sec.)	Max Power (HP)	Max Pressure (HP)	Air Consumption at Max HP SCFM (L/s)	Engagement Type**	Inlet Size (NPT)	Exhaust Size (NPT)	Gas Sealed
<b>No Lubrication Required</b>											
1 to 10	G	SS100*	E	No	15	150	415 (196)	Pre-Engaged or Inertia	1"	1 1/2"	Yes
<b>Lubrication Required</b>											
8 to 27	G	150BMG	E	No	32	150	680 (321)	Inertia	1 1/4"	1 1/4"	Yes
8 to 27	G	150BMP	E	No	32	150	680 (321)	Pre-Engaged	1 1/4"	1 1/4"	No
15 to 32	G	150BMP	D	No	32	150	680 (321)	Pre-Engaged	1 1/4"	1 1/4"	No
8 to 27	F	SS350G	E	No	36	150	900 (425)	Pre-Engaged	1 1/4"	1 1/2"	Yes
16 to 130	H	SS810	B	No	80	150	1700 (802)	Inertia	1 1/2"	2 1/2"	Yes
16 to 130	H	SS815	B	No	80	150	1700 (802)	Pre-Engaged	1 1/2"	2 1/2"	Yes
80 to 200	H	SS825	C	No	75	150	1350 (637)	Pre-Engaged	1 1/2"	2 1/2"	Yes
160 to 320	H	SS850	D	No	75	150	1275 (602)	Pre-Engaged	1 1/2"	2 1/2"	Yes

These figures are only a guide. For difficult-to-start engines or for operation under adverse conditions, use the next more powerful starter. For 2-stroke diesel engines, these figures may be multiplied by 1.5. Ex: an SS100 could be used on a 15 liter 2-stroke diesel engine. For carbureted (gas) engines, these figures may be doubled. Ex: a 150BMP could be used on a 54 liter gas engine. Note 1 liter = 61.02 in<sup>3</sup>.

\*\* There are two basic types of air starters: pre-engaged and inertia. With pre-engaged starters, the drive pinion is completely engaged with the engine ring gear before the starter begins to crank the engine. With an inertia starter, the rotating drive pinion engages the engine ring gear simultaneously with the initial cranking of the engine.

\* The SS100 is lube-free



# SS100 Series



**For engine displacement of:**  
Diesel-0 to 600 CID (0 to 10 liters)  
Carbureted-0 to 1200 CID  
(0 to 20 liters)



## Features/Benefits

- Powerful, revolutionary lube-free vane motor can be used with air or natural gas
- Alloy steel motor components ensure reliability in harsh conditions
- Offset-gear design for rugged power transfer and easy field service
- Class-leading starting torque for engines up to 10 liters
- One starter replaces the 3BM, 5BM and SS175 series

## Versatile

- One size fits engines up to 10 liters to lower cost and reduce inventory
- Compact design and flexible mounting for easy fit-up
- Standard and metric pinions fit most manufacturers' engines
- Overhung pinion and 360° flange design for easy installation
- Dependable accessories including valves, mufflers and deflectors

## Industry Applications:

MARINE



OIL & GAS



OFF-HIGHWAY



TRANSPORTATION



POWER GENERATION



### Dimensions

**SS100**

**Weight:** 28lbs (12.7 kg)

**Note:** All dimensions shown are for reference only. Specifications subject to change without notice.

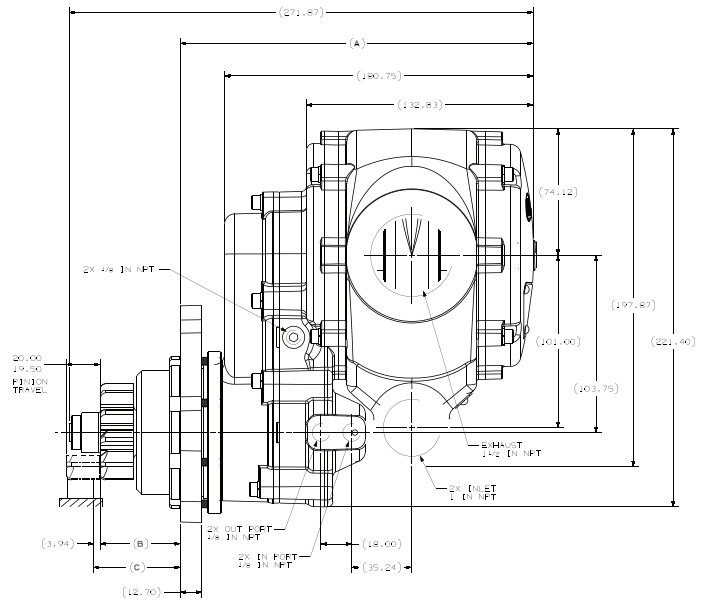
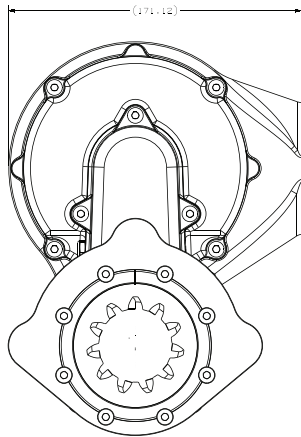

### Housing Orientations

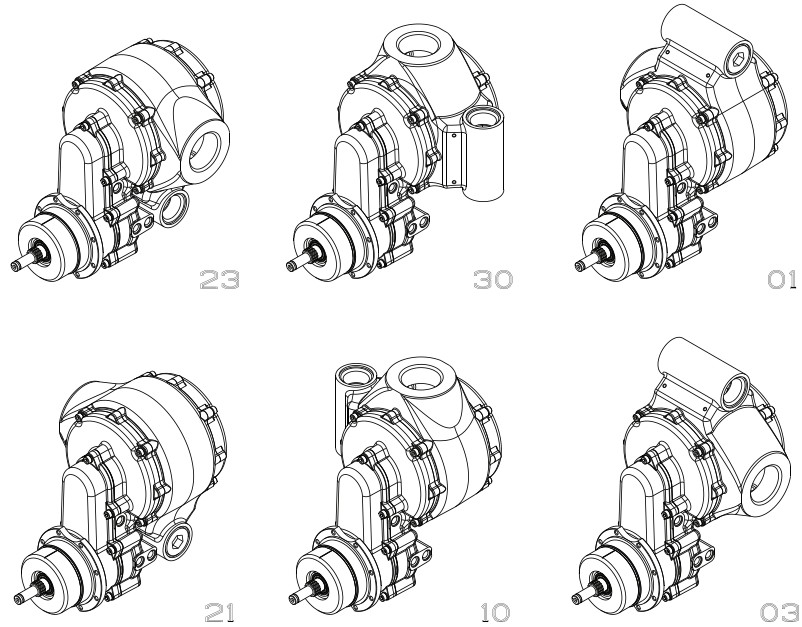
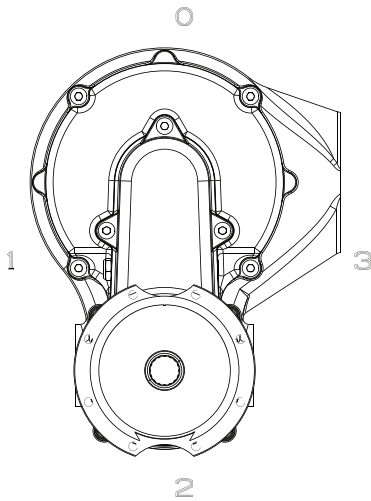

## Performance Information



Pressure PSI (bar)	Breakaway Torque ft-lb (Nm)	Speed @ Max HP RPM	Max Power HP (kw)	Flow @ Max HP SCFM (L/s)
<b>SS100</b>				
30 (2.1)	16 (22)	1290	2.3 (1.7)	110 (52)
60 (4.1)	39 (53)	1625	6.4 (4.8)	215 (101)
90 (6.2)	55 (75)	1800	9.6 (7.2)	315 (149)
120 (8.3)	75 (102)	1900	13.8 (10.3)	415 (196)
150 (10.3)	75 (102)	1900	13.8 (10.3)	415 (196)

## Model Coding

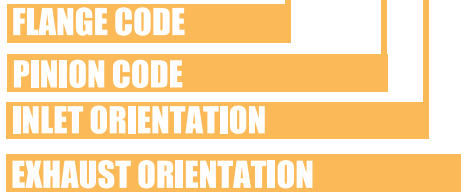
**SS100P 01 R 071-2 3**



## Parts and Accessories

	IR Part #	Description		IR Part #	Description
	SRV100	1" Relay Valve		150BMP-1051B	1/4" 12V Solenoid Valve
	SRV100-SMB	1" Relay Valve with Push Button		150BMP-2451B	1/4" 24V Solenoid Valve
	SRV150SS	1-1/2" Gas Rated Relay Valve		SMB-618	Push Button Valve
	SS350-A674	1-1/2" Muffler		SMB-G618	Push Button Valve for Natural Gas
	SS350-A735	Exhaust Deflector		ST1000-267-24	1-1/2" Stainless Steel Strainer (40 Mesh)
				ST1000-266-24	1-1/2" Strainer Element (40 Mesh)

## Genuine Ingersoll Rand Replacement Kits

Tune Up Kit Part Number	Description
SS100-TK1	Tune Up Kit
SS100-GK1	Gear Kit
SS100-TK2	Drive Housing Seal Kit
SS100-K299	Drive Kit
SS100-K299-18	Pinion Hardware Kit
SS100-K301-01	Flange Kit, SAE 01
SS100-K301-03	Flange Kit, SAE 03
SS100-K301-04	Flange Kit, SAE 04
SS100-K301-GM	Flange Kit, GM



SS100-TK1 Parts



SS100-GK1 Parts

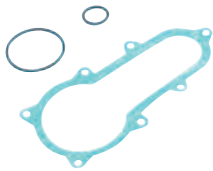

SS100-TK2 Parts



SS100-K299 Parts



SS100-K299-18 Parts



SS100-K301-01 Parts



SS100-K301-03 Parts



SS100-K301-04 Parts

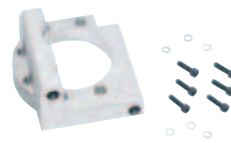

SS100-K301-GM Parts

# 150BM Series



**For engine displacement of:**  
Diesel-500 to 2000 CID (8 to 32 liters)  
Carbureted-1000 to 4000  
CID (16 to 64 liters)



## Features/Benefits

- Powerful 32 hp motor
- The leading mid-range starter design, the standard by which all others are measured
- Simple design ensures rugged dependability and ease of maintenance
- Multiple offset gear ratios: E = 3.46:1; D = 3.94:1
- Backcap ports for injection lubricating

## Versatile

- 150BMG sealed for use in air or gas applications
- Offset design for simple mounting
- Inertia and pre-engaged starters available
- 4 inlet, 4 exhaust, and 18 drive housing orientations
- 90-150 psi (6.2-10.3 bars) operation
- Left- and right-hand rotation available

## Industry Applications:

MARINE



OIL & GAS



OFF-HIGHWAY



TRANSPORTATION



POWER GENERATION



## Dimensions

### 150BMG/150BMP

**Weight:**  
 150BMG 38 lbs (17.2 kg)  
 150BMP 40 lbs (18.1 kg)

**Note:** All dimensions shown are for reference only. Specifications subject to change without notice.

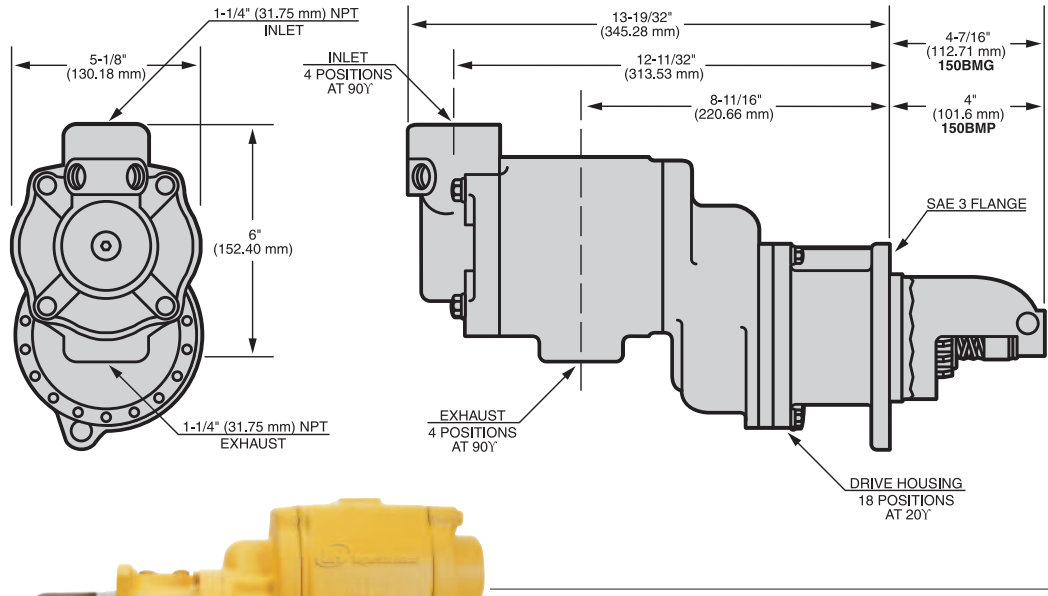

### 150BMPD

**Weight:** 40 lbs (15.9 kg)

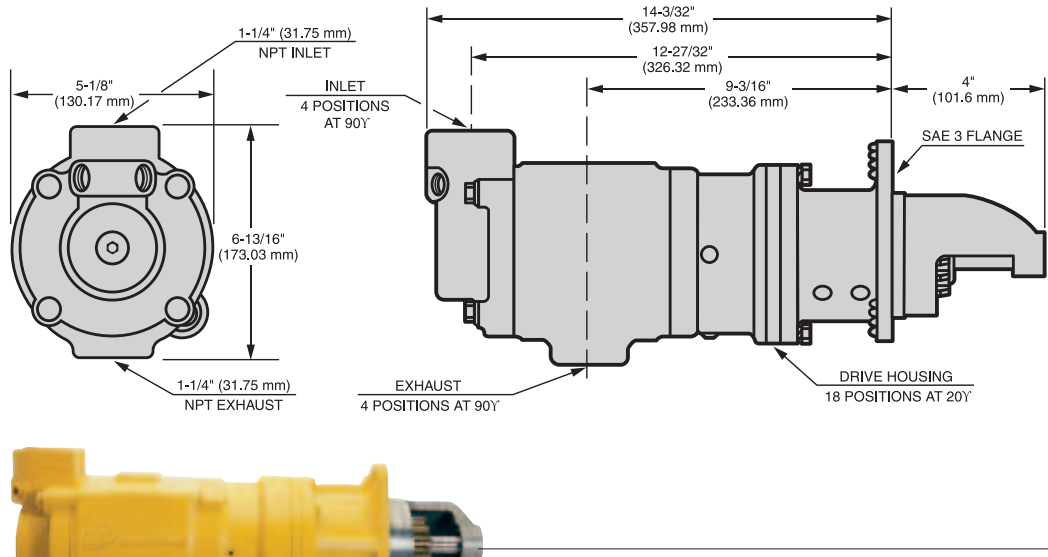

### Performance Information

Pressure PSI (bar)	Breakaway Torque ft-lb (Nm)	Speed @ Max HP RPM	Max Power HP (kw)	Flow @ Max HP SCFM (L/s)
<b>150BMGE/150BMPE</b>				
90 (6.2)	100 (136)	1700	16 (12)	380 (179)
120 (8.3)	130 (176)	1900	24 (18)	500 (236)
150 (10.3)	155 (210)	2200	32 (24)	680 (321)
<b>150BMPD</b>				
90 (6.2)	110 (149)	1500	16 (12)	370 (175)
120 (8.3)	145 (196)	1700	24 (18)	500 (236)
150 (10.3)	175 (237)	1900	32 (24)	650 (307)

### Model Coding

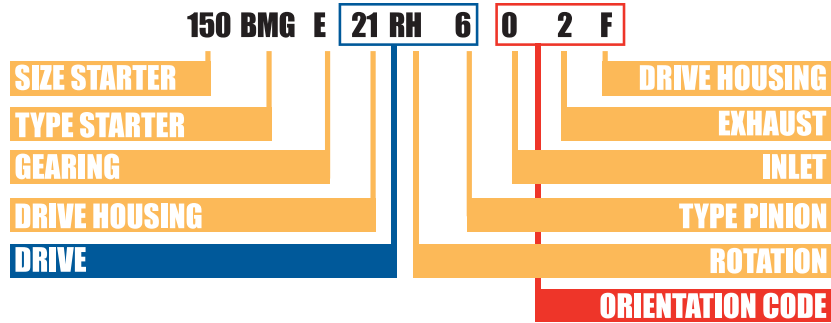



## Genuine Ingersoll Rand Replacement Kits

Tune Up Kit Part Number	Description
150BM-TK2	150BM Products
150LF-TK2	150LF Products (uses 150LF-42 vanes)
150LF-TK1	150 Motor Gasket Kit for all vane motor 150 products
150BMPD-TK1	150BMPD Products

## Parts



150LF-TK1 Parts



150BM-TK2 Parts

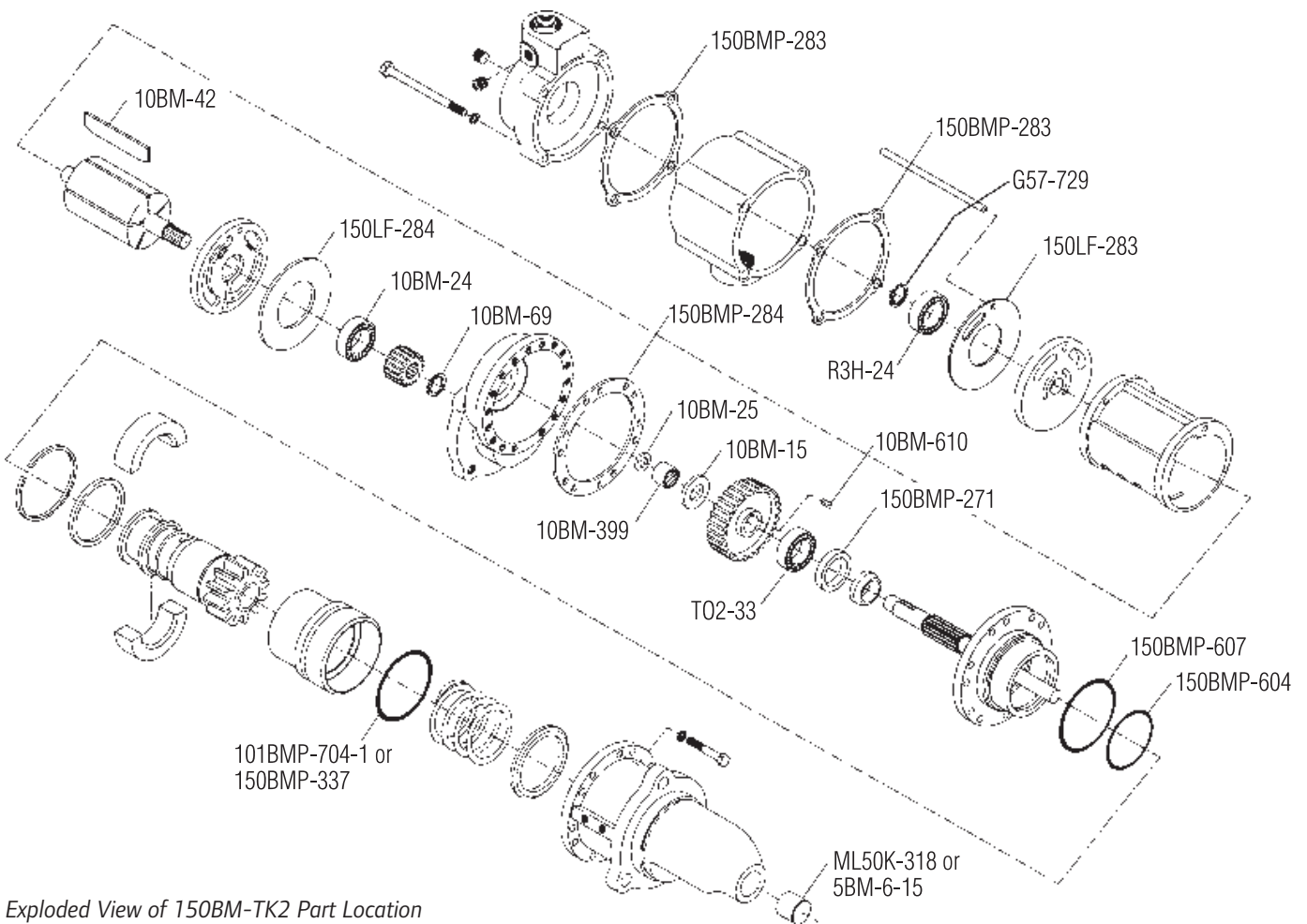

Exploded View of 150BM-TK2 Part Location

## Parts and Accessories

IR Part #	Description	IR Part #	Description
 150BM-A674	1 1/4" Muffler	 SRV125T	1-1/4" Relay Valve for Vehicular Applications
 150BMP-1051B	1/4" 12 V Solenoid Valve	 SRV125	1-1/4" Relay Valve for Stationary Applications
 150BMP-2451B	1/4" 24 V Solenoid Valve	 SRV150SS	1-1/2" Gas Rated Relay Valve
 NL-24-8	In-Line Lubricator	 150BMP-1058	Gladhand
 HDL2 (Stationary)	3/8" NPT Lubricator (1.3 cc)	 150BMP-1064	1/8", 150 psi Pressure Gauge
 HDL3 (Transportation)	3/8" NPT Lubricator (0.4 cc)	 ST1000-267-24	1-1/2" Stainless Steel Y Strainer
 SMB-G618	Gas Rated Push Button Valve	 ST1000-266-24	1-1/2" Element (40 Mesh)
 SMB-618	Push Button Valve	 150BM-A735	Road Splash Deflector

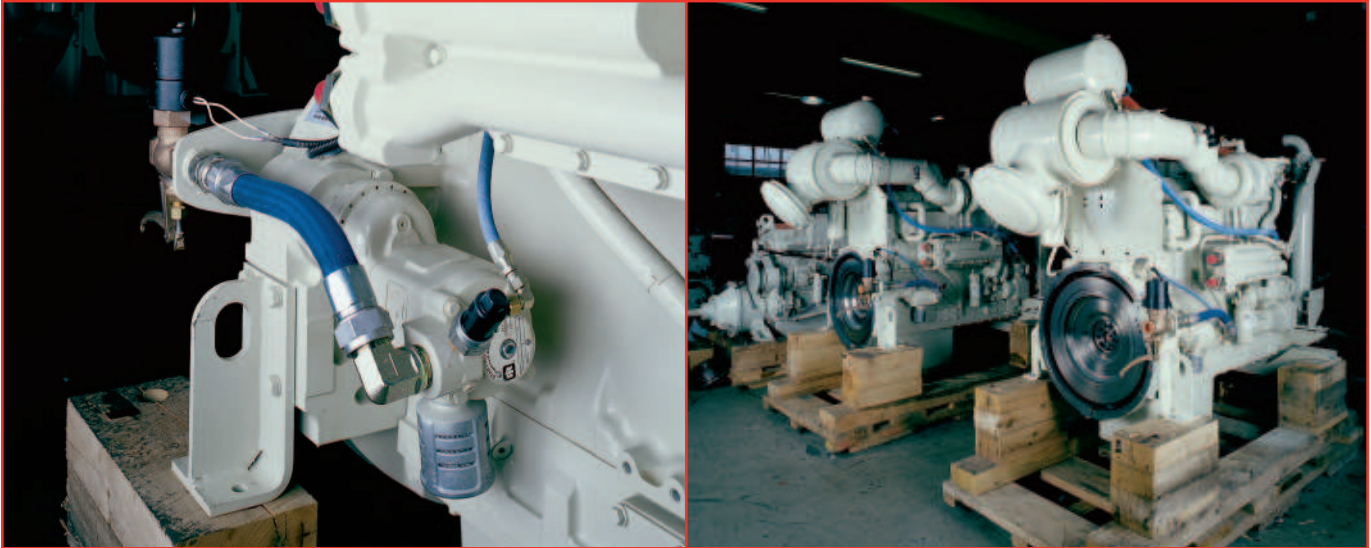

The 150BMGE21RH-6 starters are shown mounted on a Cummins KTA14-M3 and KTA19-M4I.

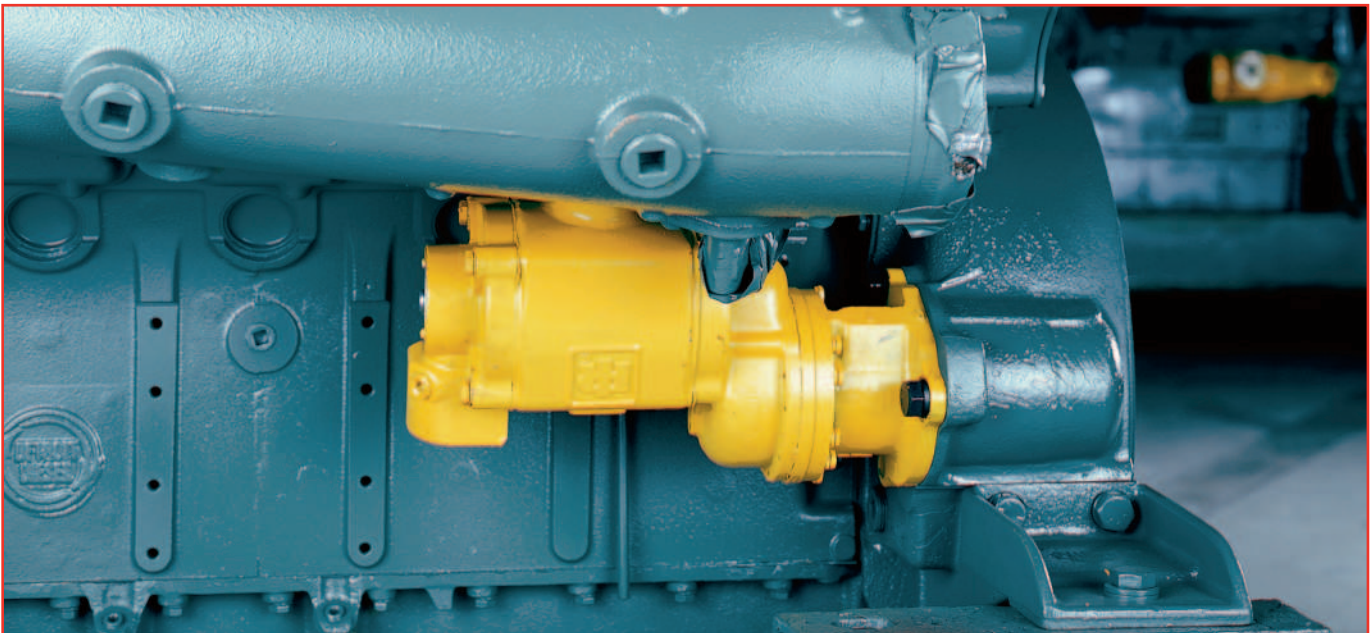

IR's genuine 150BMGE21RH-6R remanufactured starter is shown mounted on a Detroit Diesel 12V-71R.

# SS350 Series

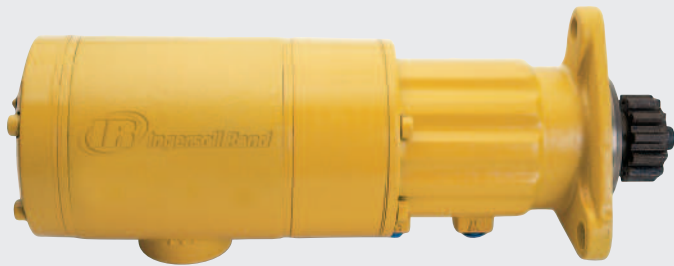

**For engine displacement of:**  
Diesel—200 to 1200 CID (3 to 20 liters)  
Carbureted—400 to 2400 CID  
(6 to 40 liters)



## Features/Benefits

- Rugged 36 hp motor on SS350
- Overhung pre-engaged pinion design for fit-up flexibility
- Backcap ports for injection lubricating

## Versatile

- Sealed for use in air or gas applications
- Compact, lightweight design makes installation easier
- Left- or right-hand rotation available
- 4 inlet, 4 exhaust, and 12 housing orientations
- 30-150 psi (2.1-10.3 bars) operation
- SAE 01 and SAE03 mounting flanges fit most worldwide manufacturers' engines

## Industry Applications:

MARINE



OIL & GAS



OFF-HIGHWAY



TRANSPORTATION



POWER GENERATION



## Dimensions

### SS350G

**Weight:** 33 lbs (15.0 kg)

**Note:** All dimensions shown are for reference only. Specifications subject to change without notice.

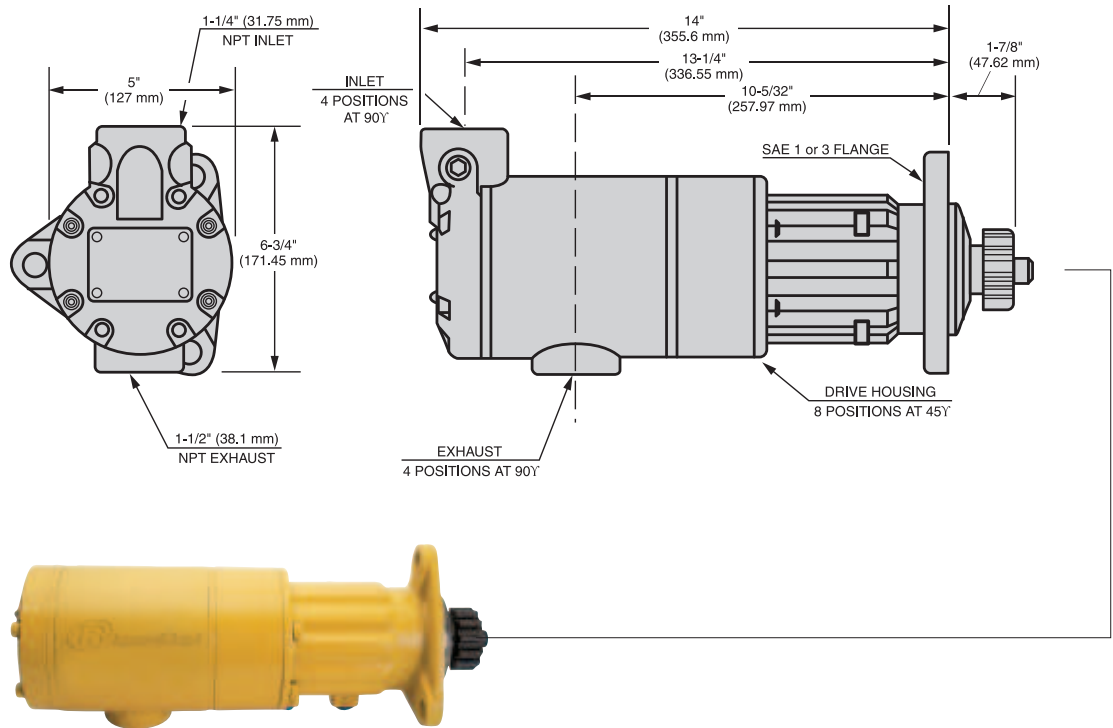

## Model Coding

**SS350 G E 03 R 31 XX 024**

<b>SIZE STARTER</b>	<b>ORIENTATION</b>
<b>GAS SEALED</b>	<b>SR=SPARK RESISTANT</b>
<b>GEAR RATIO</b>	<b>PINION CODING</b>
<b>SAE No. MOUNTING FLANGE</b>	<b>ROTATION L or R</b>

## Performance Information

Pressure PSI (bar)	Breakaway Torque ft-lb (Nm)		Speed @ Max HP RPM		Max Power HP (kw)	Flow @ Max HP SCFM (L/s)
	B Ratio	E Ratio	B Ratio	E Ratio		
90 (6.2)	70 (95)	100 (136)	2900	2000	19 (14)	525 (248)
120 (8.3)	90 (122)	130 (176)	3100	2200	27 (20)	750 (354)
150 (10.3)	110 (149)	160 (217)	3400	2400	36 (27)	900 (425)

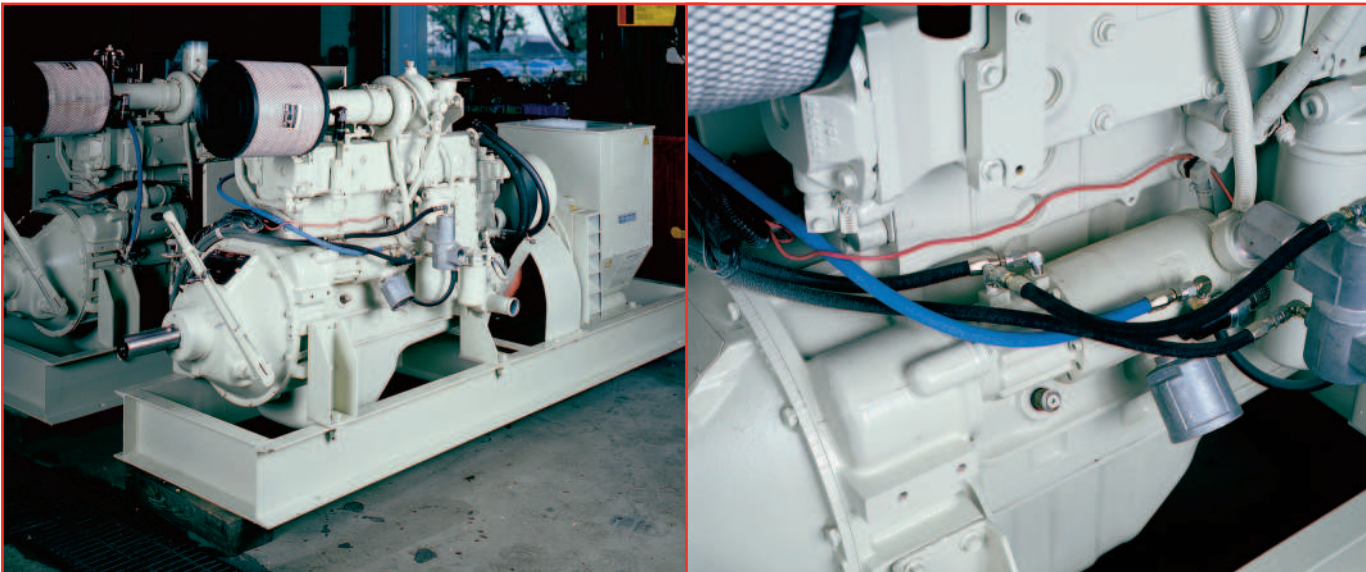

The SS350GE03R29 starter is mounted on a Cummins M14TA to be used as a marine generator set.

## Genuine Ingersoll Rand Replacement Kits

Tune Up Kit Part Number	Description
SS350-TK2	SS350 Tune Up Kit

### Parts

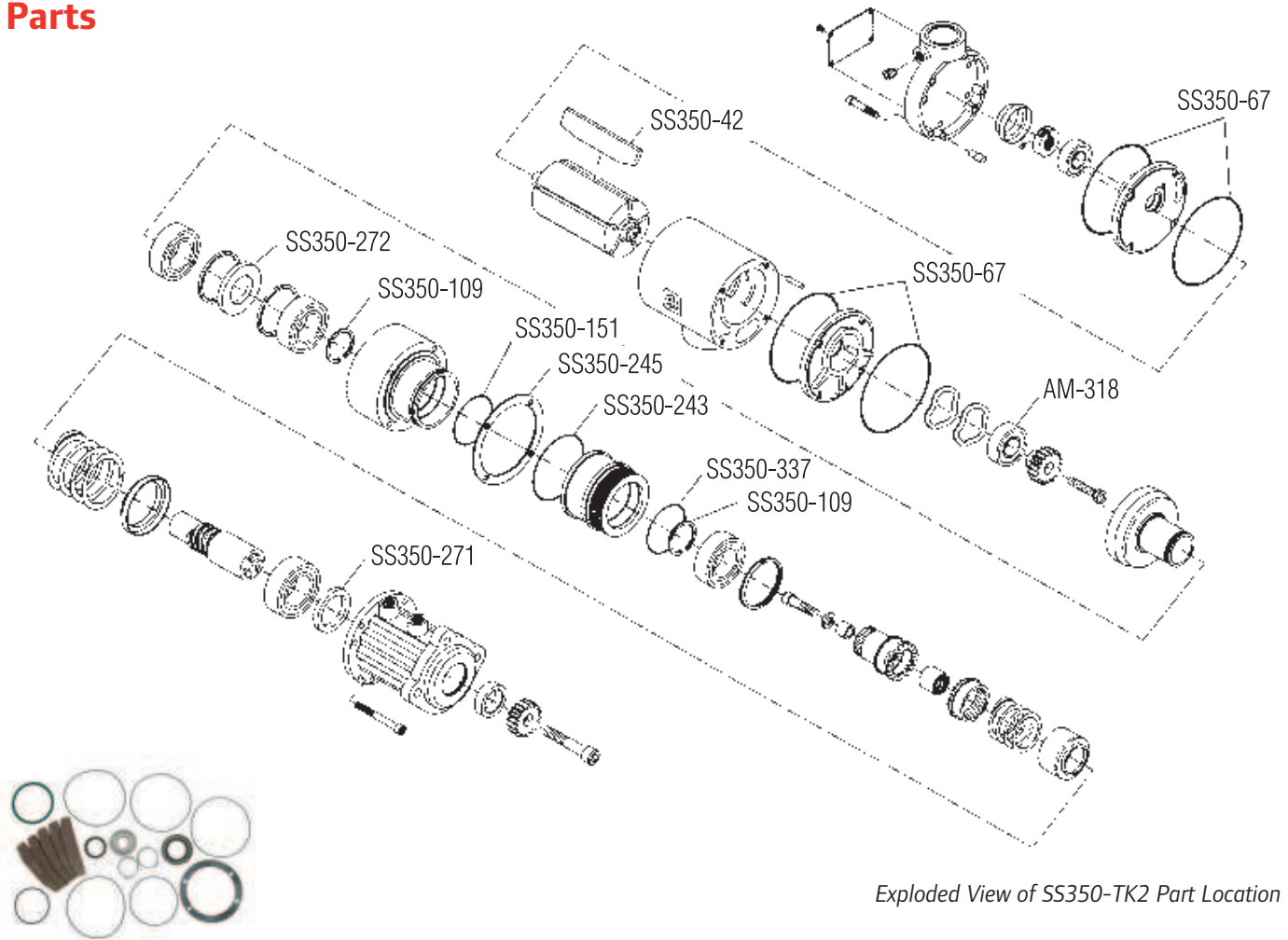

Exploded View of SS350-TK2 Part Location



SS350-TK2 Parts

## Parts and Accessories

	IR Part #	Description		IR Part #	Description
	SS350-A674	1 1/2" Muffler		SRV125T	1-1/4" Relay Valve for Vehicular Applications
	150BMP-1051B	1/4" 12 V Solenoid Valve		SRV125	1-1/4" Relay Valve for Stationary Applications
	150BMP-2451B	1/4" 24 V Solenoid Valve		SRV150SS	1-1/2" Gas Rated Relay Valve
	NL-24-8	In-Line Lubricator		150BMP-1058	Gladhand
	HDL2 (Stationary)	3/8" NPT Lubricator (1.3 cc)		150BMP-1064	1/8", 150 psi Pressure Gauge
	HDL3 (Transportation)	3/8" NPT Lubricator (0.4 cc)		ST1000-267-24	1-1/2" Stainless Steel Y Strainer
	SMB-G618	Gas Rated Push Button Valve		ST1000-266-24	1-1/2" Element (40 Mesh)
	SMB-618	Push Button Valve		150BMP-1056	1/2" Check Valve



# SS800 Series



**For engine displacement of:**  
Diesel—1000 to 20,000 CID (16 to 320 liters)  
Carbureted—2000 to 40,000  
CID (32 to 640 liters)



## Features/Benefits

- Powerful 75 hp motor
- The leading large-frame starter design, the standard by which all others are measured
- Simple design ensures rugged dependability and ease of maintenance
- Multiple offset gear ratios: B = 2.18:1; C = 2.53:1; D = 3.44:1
- Backcap ports for injection lubricating

## Versatile

- All models sealed for use in air or gas applications
- Offset design for simple mounting
- Inertia (SS810) and pre-engaged (SS815, SS825 and SS850) starters available
- 4 inlet, 4 exhaust, and 16 drive housing orientations
- 90-150 psi (6.2-10.3 bars) operation
- Left- and right-hand rotation available

## Industry Applications:

MARINE



OIL & GAS



OFF-HIGHWAY



TRANSPORTATION



POWER GENERATION



## Dimensions

### SS810G

Weight: 93 lbs (42.2 kg)

Note: All dimensions shown are for reference only. Specifications subject to change without notice.

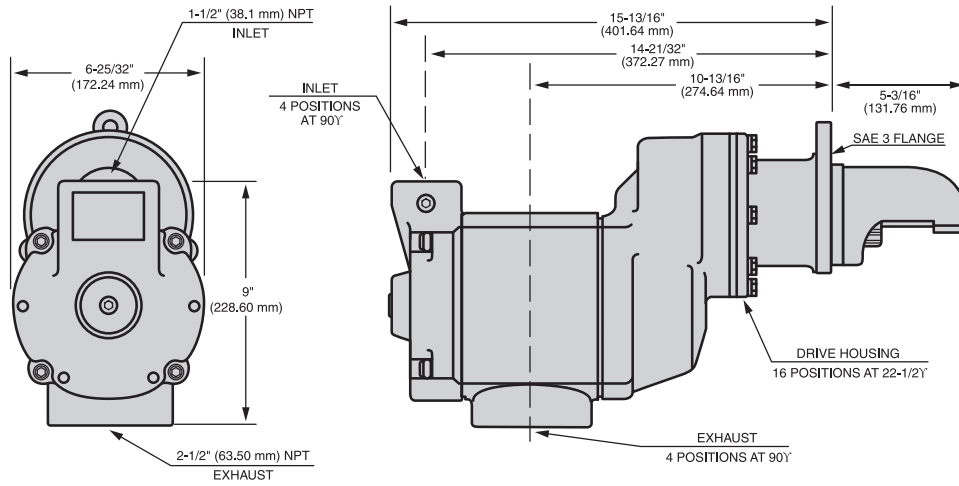

### SS815G and SS825G

Weight:

SS815G 93 lbs (31.3 kg)

SS825G 95 lbs (43.1 kg)

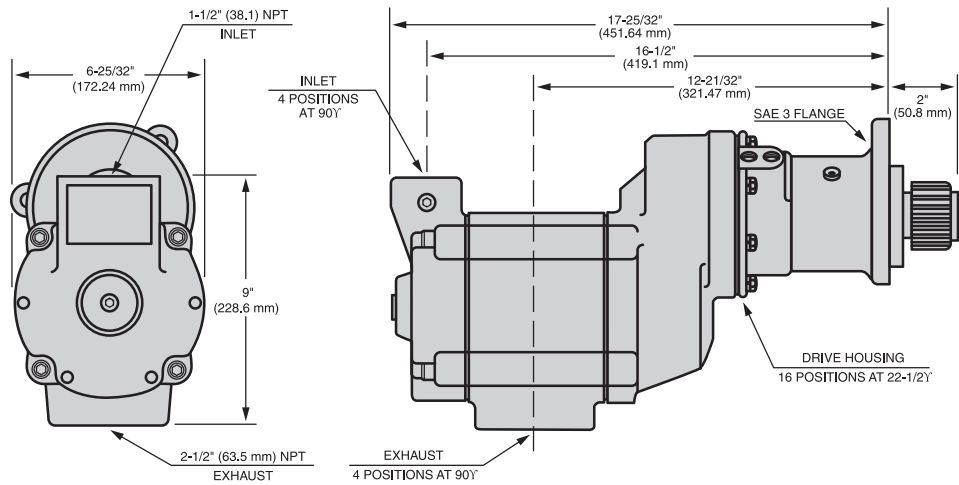

### SS850G

Weight: 123 lbs (55.8 kg)

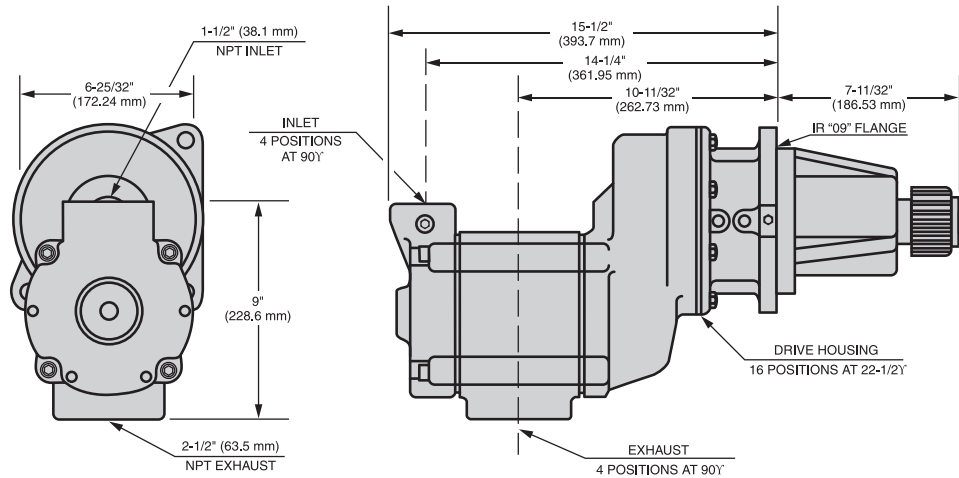

## Performance Information

Pressure PSI (bar)	Breakaway Torque ft-lb (Nm)	Speed @ Max HP RPM	Max Power HP (kw)	Flow @ Max HP SCFM (L/s)
<b>SS810 and SS815</b>				
90 (6.2)	170 (230)	2700	45 (34)	1100 (519)
120 (8.3)	205 (278)	2800	58 (43)	1250 (590)
150 (10.3)	250 (339)	3200	75 (56)	1700 (802)
<b>SS825</b>				
90 (6.2)	200 (271)	2300	45 (34)	900 (425)
120 (8.3)	240 (325)	2400	58 (43)	1100 (519)
150 (10.3)	300 (407)	2700	75(56)	1700 (802)
<b>SS850</b>				
90 (6.2)	260 (352)	1600	45 (34)	800 (378)
120 (8.3)	340 (461)	1800	58 (43)	1000 (472)
150 (10.3)	415 (562)	1900	75(56)	1275 (602)

## Model Coding

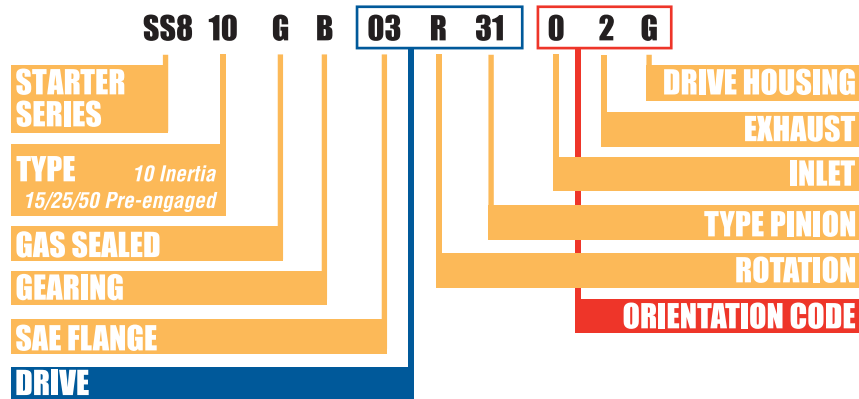

## Genuine Ingersoll Rand Replacement Kits

Tune Up Kit Part Number	Description
SS800-TK2	SS815 and SS825 Tune Up Kit
SS810-TK2	SS810 Tune Up Kit
SS810-TK2	SS850 Tune Up Kit

### Parts

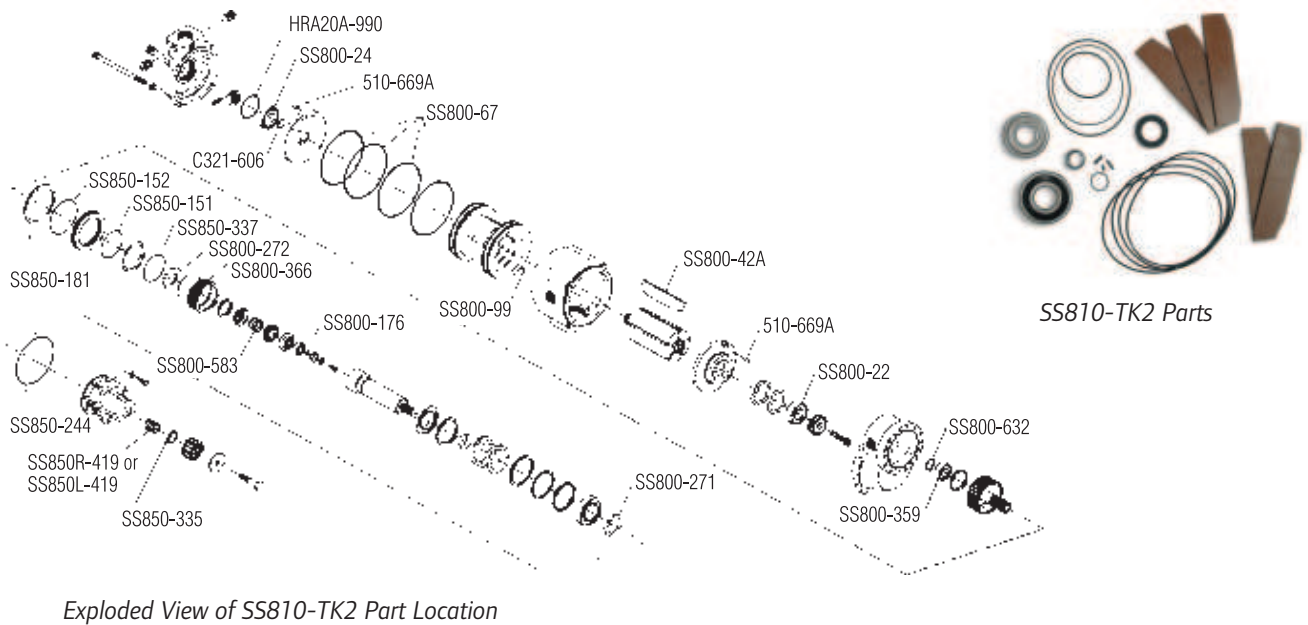
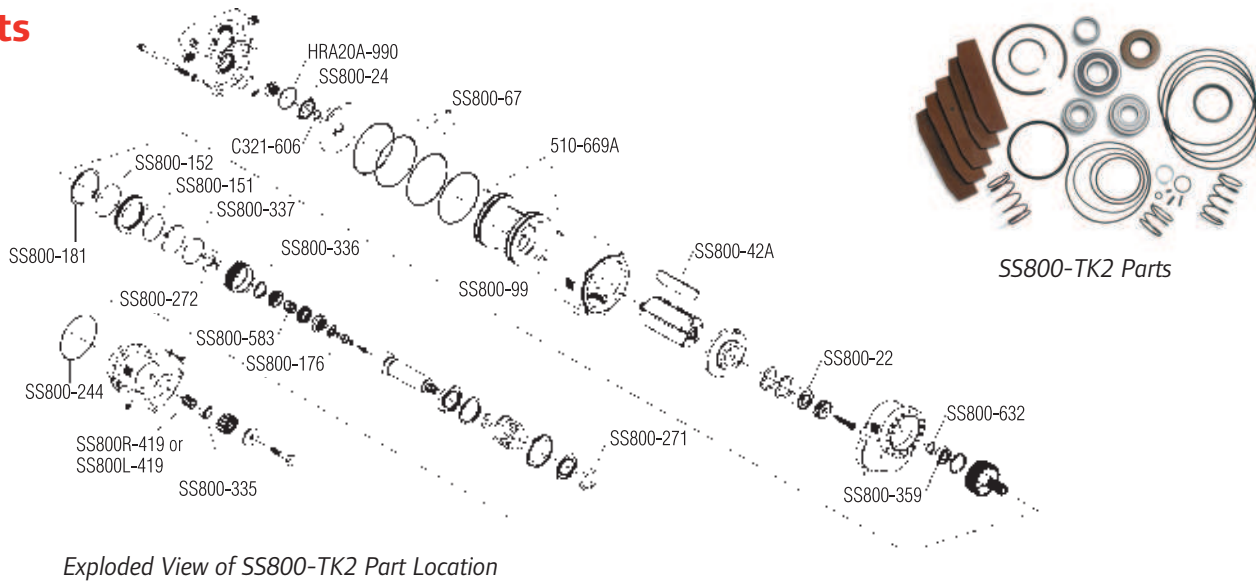

## Parts and Accessories

IR Part #	Description	IR Part #	Description
 SS800-A674	2-1/2" Muffler	 SRV150	1-1/2" Relay Valve for Air Applications
 150BMP-1051B	1/4" 12 V Solenoid Valve	 SRV150SS	1-1/2" Gas Rated Relay Valve
 150BMP-2451B	1/4" 24 V Solenoid Valve	 150BMP-1058	Gladhand
 NL-24-8	In-Line Lubricator	 HDL2 (Stationary)	3/8" NPT Lubricator (1.3 cc)
 HDL3 (Transportation)	3/8" NPT Lubricator (0.4 cc)	 150BMP-1064	1/8", 150 psi Pressure Gauge
 SMB-G618	Gas Rated Push Button Valve	 ST1000-267-24	1-1/2" Stainless Steel Y Strainer
 SMB-618	Push Button Valve	 ST1000-267-32	2" Stainless Steel Y Strainer
		 ST1000-266-24	1-1/2" Element (40 Mesh)
		 ST1000-266-32	2" Element (40 Mesh)



IR's genuine SS810GB03R31R inertia remanufactured starter is shown mounted on a Detroit Diesel 16V-71R.

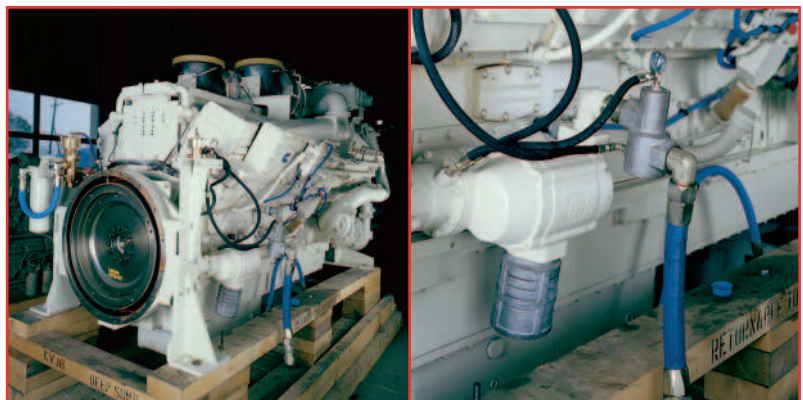

The SS815GB03R31 starter is shown mounted on a Cummins KTA50-M2 piped with the IR SRV150 Relay Valve.

# TS700/TS900/TS1400 Series

Starters for Gas Turbine Engines



## Features/Benefits

- Powerful turbine motors up to 146HP require no external lubrication
- Sealed oil-bath system internally lubricates the planetary gears and motor bearings
- Air cooling extends bearing and seal life
- No internal or external shut-off devices

## Versatile

- Multiple spline pinions
- Multiple gear ratios for matching the optimum engine characteristics
- Multiple flange options
- Gas-sealed for application flexibility

## Industry Applications:

OIL & GAS



POWER GENERATION



## Dimensions

### TS725/TS750GBBE-LE

**Weight:**

TS725GBBE-LE 80 lbs (36.3 kg)

TS750GBBE-LE 80 lbs (36.3 kg)

**Note:** All dimensions shown are for reference only. Specifications subject to change without notice.

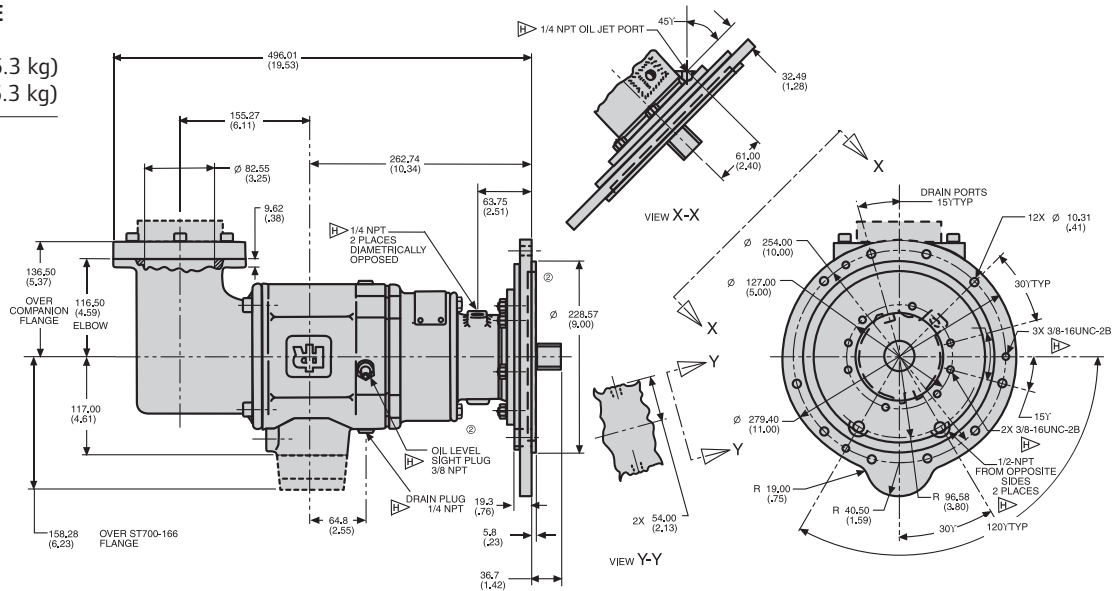

### TS725GBDE-LE

**Weight:** 80 lbs (36.3 kg)

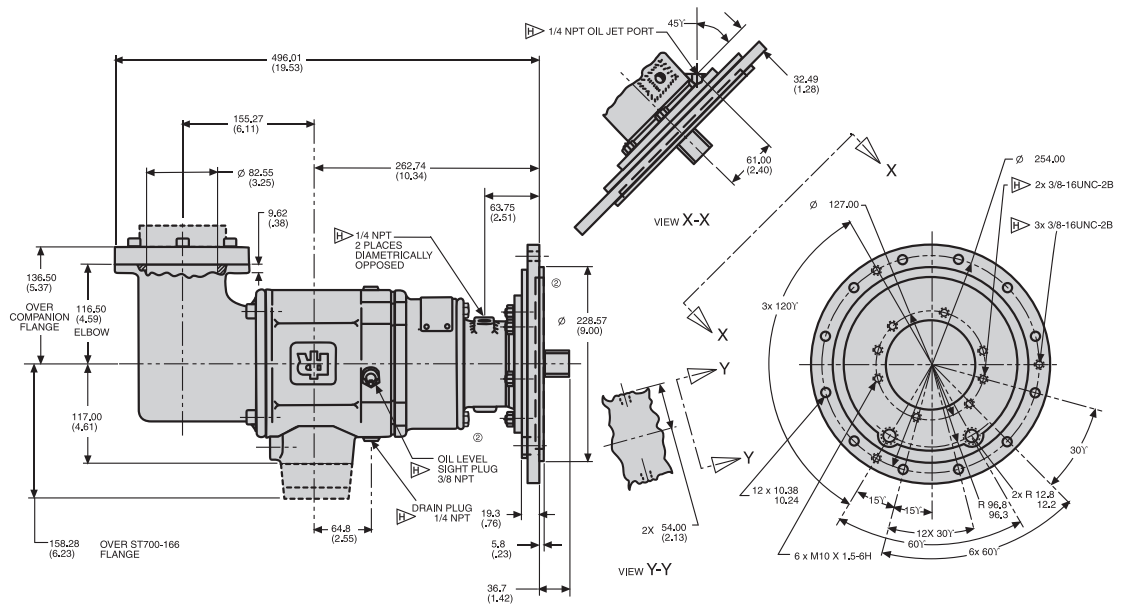

### Inlet Flange Kit (ST700-K166)

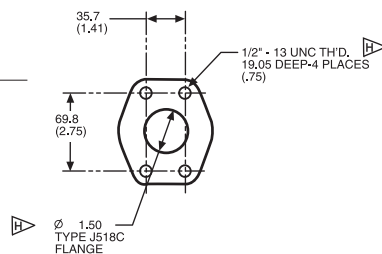

## Dimensions

### TS799BBEF-LE

Weight: 70 lbs (31.8 kg)

Note: All dimensions shown are for reference only. Specifications subject to change without notice.

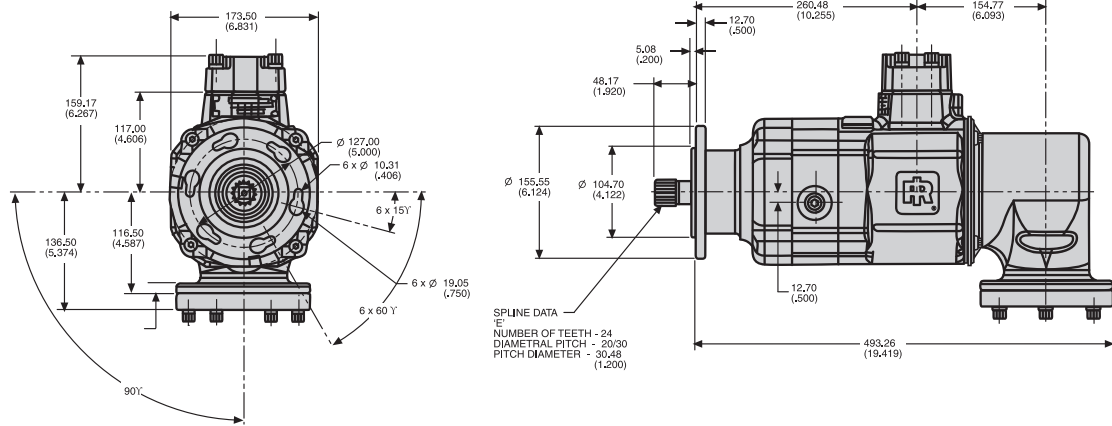

### TS799BBEF-LM

Weight: 62 lbs (28.1 kg)

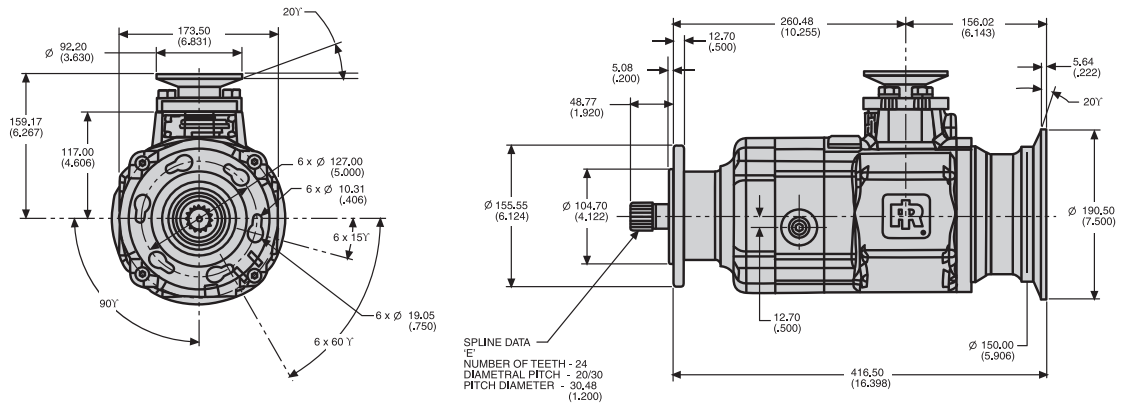



## Dimensions

### TS799GBFD-L

Weight: 70 lbs (31.8 kg)

Note: All dimensions shown are for reference only. Specifications subject to change without notice.

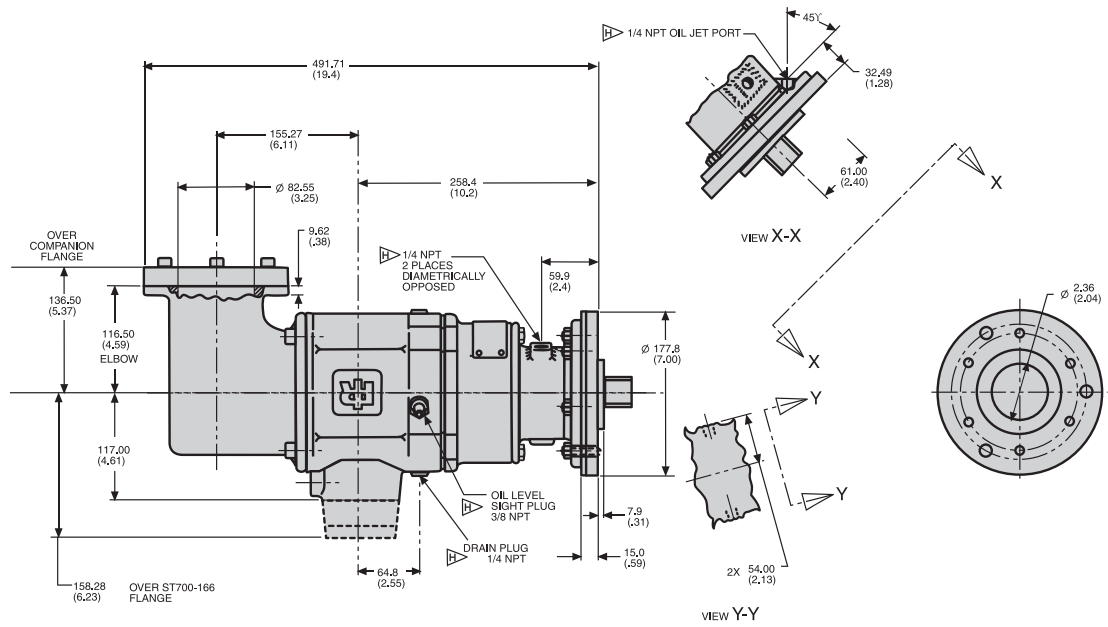

### TS999GZCD-LE

Weight: 70 lbs (31.8 kg)

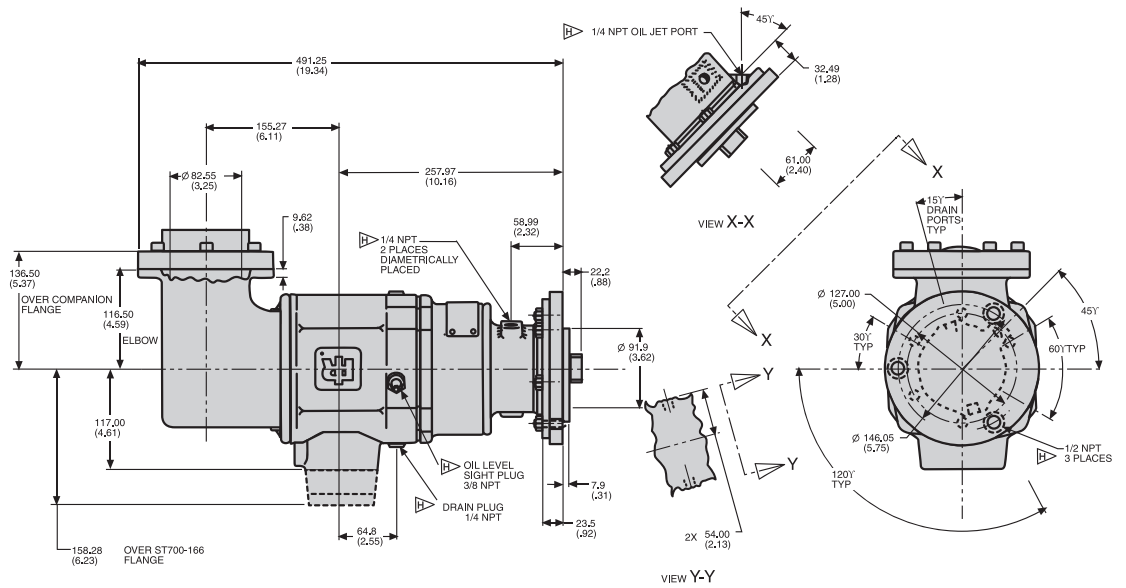

## Dimensions

### TS999GZFA-L

Weight: 58 lbs (26.3 kg)

Note: All dimensions shown are for reference only. Specifications subject to change without notice.

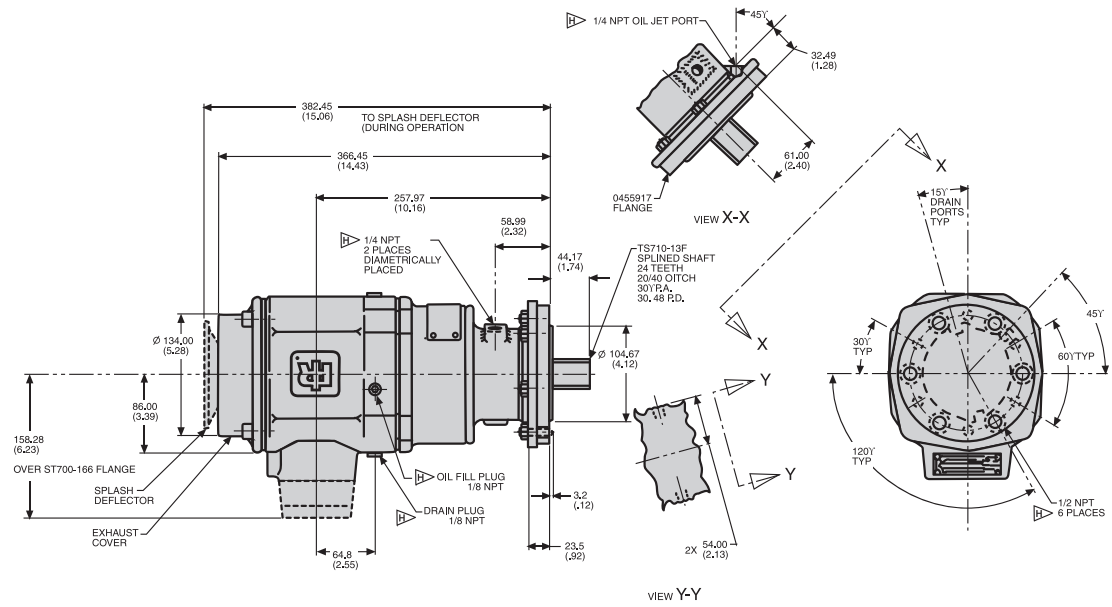

### TS1400 Turbine Units

Weight: 124 lbs (56.2 kg)

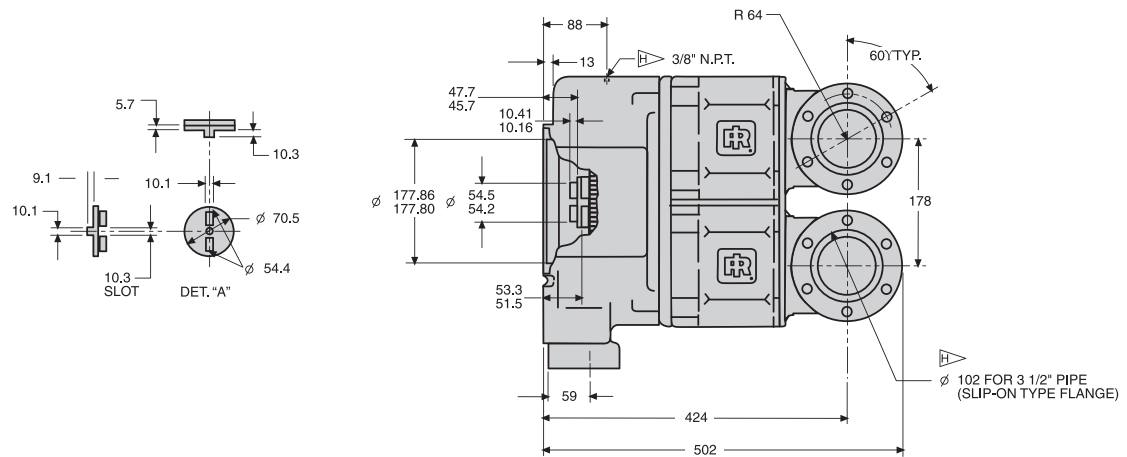

## Single Motor Performance Information

Pressure PSI (bar)	Breakaway Torque ft-lb (Nm)	Speed @ Max HP RPM	Max Power HP (kw)	Flow @ Max HP SCFM (L/s)
<b>TS725</b>				
90 (6.2)	110 (149)	2000	18 (13)	330 (156)
150 (10.3)	180 (243)	2300	40 (30)	515 (243)
225 (15.5)	270 (365)	2500	65 (49)	750 (354)
<b>TS750</b>				
90 (6.2)	170 (230)	2200	30 (22)	850 (401)
120 (8.3)	240 (325)	2300	50 (37)	990 (467)
150 (10.3)	300 (407)	2500	70 (52)	1210 (571)
<b>TS799G</b>				
60 (4.1)	250 (339)	2400	55 (41)	1050 (496)
90 (6.2)	310 (420)	2500	70 (52)	1400 (661)
<b>TS799B</b>				
150 (10.3)	570 (773)	2500	130 (97)	2200 (1038)
<b>TS999</b>				
90 (6.2)	125 (169)	5500	71 (53)	1300 (614)

## Dual Motor Performance Information

IR Part Number	Solar Part Number	Max Pressure PSI (bar)	Breakaway Torque ft-lb (Nm)	Speed @ Max HP RPM	Max Power HP (kw)	Flow @ Max HP SCFM (L/s)	Motor Arc
<b>TS1400</b>							
TS1401-102	190475-102	225 (15.5)	420 (567)	3100	124 (93)	1700 (802)	25%
TS1435	190475-301	225 (15.5)	459 (620)	3882	141 (105)	1900 (896)	35%
TS1450	190475-401	150 (10.3)	506 (683)	3034	146 (109)	2500 (1179)	50%

## TS Engine Selection Guide

Engine	IR Part Number	Solar Part Number	Max Pressure PSI (bar)
Solar Saturn	TS725GBBE-LE	190716-200	225 (15.5)
	TS725GBDE-LE	190716-100	225 (15.5)
	TS750GBBE-LE	-	150 (10.3)
Solar Centaur	TS1435	190475-301	225 (15.5)
	TS1450	190475-401	180 (12.2)
	TS1401-102	190475-102	225 (15.5)
Solar Taurus	TS1435	190475-301	225 (15.5)
	TS1450	190475-401	180 (12.2)
	TS1401-102	190475-102	225 (15.5)
Allison 570	TS799GBFD-L	-	90 (6.2)
Allison 501-KC	TS999GZFA-L	-	90 (6.2)
Allison 501-KB	TS999GZFA-L	-	90 (6.2)
Garret IE831	TS999GZCD-LE	-	90 (6.2)
Pratt & Whitney GG3/F13, GG4/G14	TS799BBEF-LE	-	150 (10.3)
	TS799BBEF-LM	-	150 (10.3)

This chart is a condensed list of engines that can be cranked with an IR starter. For a complete list, please contact IR.



## TS700/TS900 Output Spline Data



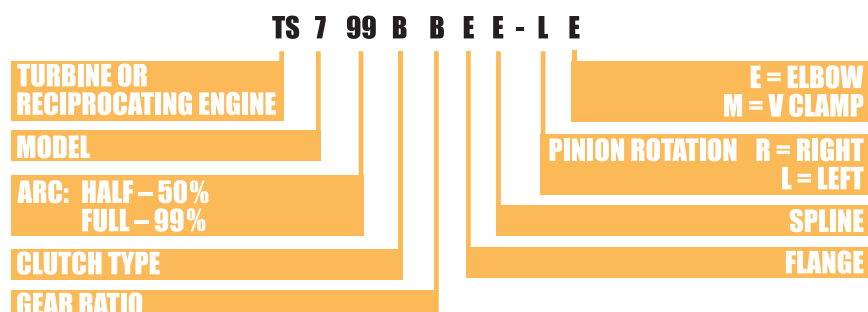

TS Part Number	Shaft Output Part Number	Teeth	Diametral Pitch	Pressure Angle	Pitch Diameter
TS725GBBE-LE	TS710-13E	24	20/30	30	30.48
TS725GBDE-LE	TS710-13E	24	20/30	30	30.48
TS750GBBE-LE	TS710-13E	24	20/30	30	30.48
TS799BBEF-LE	TS799-18E	24	20/30	30	30.48
TS799BBEF-LM	TS799-18E	24	20/30	30	30.48
TS799GBFD-L	4612834	16	20/30	30	20.32
TS999GZCD-LE	4612834	16	20/30	30	20.32
TS999GZFA-L	TS710A-13F	24	20/40	30	30.48

## Model Coding

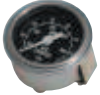

## Parts and Accessories

IR Part #	Description
 SRV150	1-1/2" Relay Valve for Air Applications
 SRV150SS	1-1/2" Gas Rated Relay Valve
 150BMP-1064	1/8", 150 psi Pressure Gauge

IR Part #	Description
 ST900-267-24	1-1/2" Strainer (300 Mesh)
 ST900-267-32	2" Strainer (300 Mesh)
 ST900-266-24	1-1/2" Strainer Element (300 Mesh)
 ST900-266-32	2" Strainer Element (300 Mesh)

## Genuine Ingersoll Rand Replacement Kits

Tune Up Kit Part Number	Description
<b>TS1400</b>	
TS1400-TK1	Seal and O-Ring Kit
TS1401-RM1	Seals, Bearings, and 2-25% Arc Motors
TS1401-RM2	Seals, Bearings, and 2-99% Arc Motors
TS1401-RM3	Seals, Bearings, and 2-35% Arc Motors
TS1401-RM4	Seals, Bearings, and 2-50% Arc Motors
TS1401-TK1	Seal and O-Ring Kit

Tune Up Kit Part Number	Description
<b>TS700</b>	
TS700-RM1	Bearing and O-Ring Kit (includes TS700-TK1)
TS700-TK1	O-Ring Kit

# Barring Motors Series



**For engine displacement of:**  
Diesel—up to 30,500 CID (500 liters)  
Carbureted—up to 61,000 CID  
(1000 liters)



## Features/Benefits

- Reversible vane air motor for precise control
- Rugged design provides maximum durability and dependability
- Pendant control enables safer one-person operation
- B006 for diesel engines with displacements up to 100 liters and gas engines up to 200 liters
- T480 for diesel engines with displacements up to 500 liters and gas engines up to 1000 liters
- Integral disc brake on T480 is always engaged when motor is not in operation to ensure safer, easier engine adjustments

## Versatile

- Available in two sizes
- Turns clockwise and counterclockwise at full power
- Can be used as a portable service tool or be permanently mounted to the engine
- Uses standard motor and pinion components
- Adjustable mounting flange allows multiple orientations

## Industry Applications:

MARINE



OIL & GAS



OFF-HIGHWAY



TRANSPORTATION



POWER GENERATION



## Performance Information

Model	Flange	Weight lb (kg)	Max Pressure (motor inlet) psi (bar)	Breakaway Torque ft-lb (Nm)	Speed at Max Power rpm	Description
<b>B006</b>						
B006PVR374-01**	01	19 (9)	90 (6)	152 (207)	23	Barring Motor Only
B006PVR374-03**	03	19 (9)	90 (6)	152 (207)	23	Barring Motor Only
B006PVR374-01-***P	01	25 (11)	90 (6)	152 (207)	23	Barring Motor with Pendant Control
B006PVR374-03-***P	03	25 (11)	90 (6)	152 (207)	23	Barring Motor with Pendant Control
**Pinion configurations: 15, 29, 31, 77, 79, 85, 94, 893, 895, 942. Additional flange and pinion configurations available upon request.						
<b>T480 : Includes integral brake</b>						
T480PVRP-03**	03	58 (26)	90 (6)	322 (438)	65	Barring Motor Only
T480PVRP-03-***P	03	58 (26)	90 (6)	322 (438)	65	Barring Motor with Pendant Control
**Pinion configurations: 25, 29, 31, 83, 85, 87, 94, 893, 895, 942. Additional flange and pinion configurations available upon request.						

## Parts and Accessories

IR Part #	Description
PB006-15K	B006 Pendant Control & 2 Hoses (15' / 4.6m each)
PB006-30K	B006 Pendant Control & 2 Hoses (30' / 9m each)
43551-2	Muffler for B006
PT480-15K	T480 Pendant Control & 3 Hoses (15' / 4.6m each)
PT480-30K	T480 Pendant Control & 3 Hoses (30' / 9m each)
3BM-A674	Muffler for T480



A B006PVR374-03-31P barring motor using pendant control, slow turning a Caterpillar 3408 engine.

## Accessories Index By Description

Accessory Description	IR Part #	Page #
<b>Relay Valves</b>	SRV100	<b>M2 – M3</b>
	SRV125	
	SRV125T	
	SRV125F	
	SRV150	
	SRV150SS	
<i>Relay Valve Tune Up Kit</i>	SRV150-TK3	
<b>Solenoid Control Valves</b>	150BMP-1051B	<b>M4 – M5</b>
	150BMP-2451B	
	150BMP-6451B	
	150BMP-A1051B	
<i>Angle Mounting Bracket</i>	150BMP-B2451	
	ST400-A339M	
	ST400-C339	
<i>ST400 Repair Kit</i>	ST400-K619	
<b>Push Button Control Valves</b>	SMB-618	<b>M6</b>
	SMB-G618	
	SMB-619	
<i>White Push Button Replacement</i>	SMB-620	
<i>Black Push Button Replacement</i>		

Accessory Description	IR Part #	Page #
<b>Air Strainers</b>	ST900-267-16	<b>M7 – M8</b>
	ST900-267-24	
	ST900-267-32	
	ST900-267-64	
	ST1000-267-24	
	ST1000-267-32	
<b>Mufflers</b>	3BM-WM07	<b>M9</b>
	3BM-A674	
	150BM-A674	
	SS350-A674	
	ST500-674	
	SS800-A674	
<b>Regulators</b>	NR-24-8	<b>M10 – M11</b>
<i>NR-24-8 Tune Up Kit</i>	NR24-TK1	
<b>In-Line Lubricators</b>	NL-8-8	<b>M12 – M13</b>
	NL-24-8	



# Relay Valves

Ingersoll Rand Relay Valves provide immediate response to assure Air Starter disengagement and prevent damage to the pinion or flywheel ring gear. The aluminum die cast housing resists abrasion and corrosion while the stainless steel piston return spring will not rust from moisture in the air line.



SRV150



SRV150SS



SRV125F-P

## Specifications

- Maximum Operating Pressure = 225 psi (15.5 bar)
- Operating Temperature Range = -20 to 250°F (-29 to 121°C)
- Flow/Pressure Drop  $C_v = 37$

## Relay Valves

IR Part Number	NPT Size Inlet – Outlet	Weight – lb (kg)	Description
SRV100	1" – 1"	3.10 (1.41)	3BMG, 5BMG, SS175G Relay Valve
SRV125	1-¼" – 1 ¼"	2.90 (1.32)	150BM, SS350G, 150T Relay Valve
SRV125T	1-¼" – 1 ¼"	2.90 (1.32)	150BM, SS350G, 150T Relay Valve for Transportation
SRV150	1½" – 1½"	2.70 (1.22)	SS800, ST700, ST900, ST600 Relay Valve
SRV150SS	1½" – 1½"	7.15 (3.24)	SS800, ST700, ST900 Relay Valve for Natural Gas Use
SRV125F-P	1-¼" Flanged	7.40 (3.36)	150T/150BM 150T/150BM Flange Mount Relay Valve

## Inlet Pressure vs. Pilot Pressure to Open

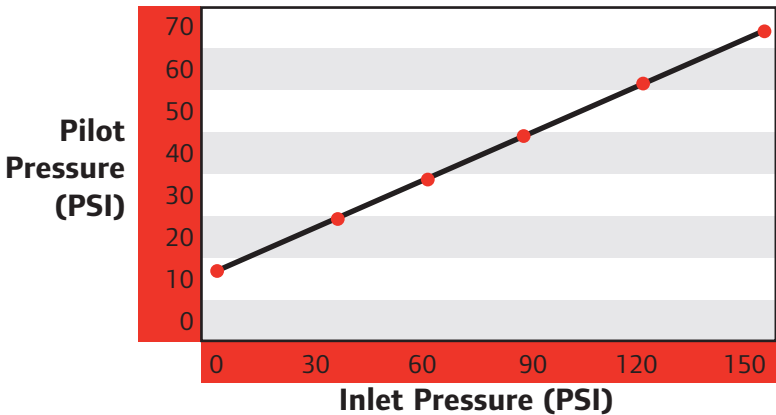

### Dimensions

**Note:** All dimensions shown are for reference only. Specifications subject to change without notice.

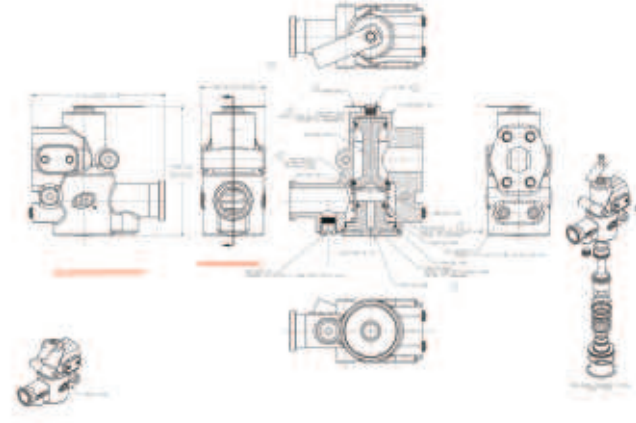
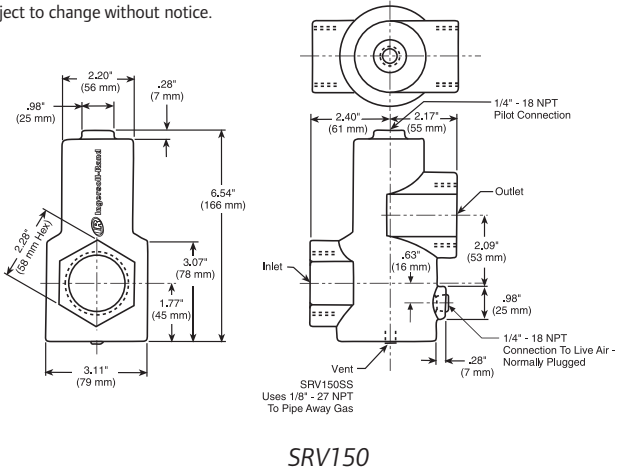

SRV150

SRV125F-P

### Genuine Ingersoll Rand Replacement Kits

Tune Up Kit Part Number	Description
SRV150-TK3	For use with SRV100, SRV125, SRV125T, SRV150, and SRV150SS Relay Valves

### Parts

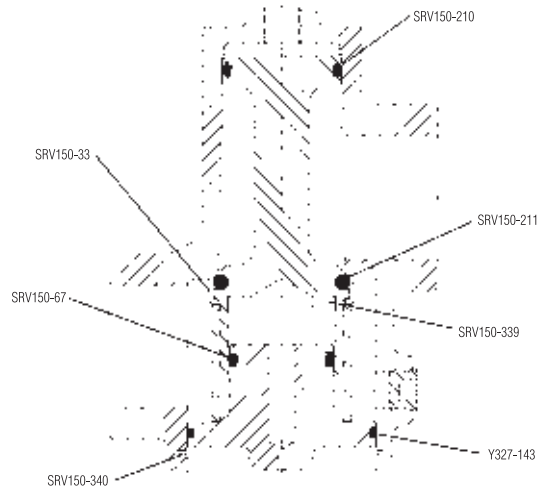

Cross-Section of SRV150-TK3 Part Location



SRV-TK3 Parts

# Solenoid Control Valves

These DC electrically actuated valves are designed for pilot operation of the Ingersoll Rand relay valve and are approved for applications affected by the U.S. Department of Transportation safety codes.

## Specifications

- Valve Type: Three-way normally closed  $C_v$  Factor: 0.21
- Power Consumption: 25 watts
- Operating Pressure Range: 0 to 300 psig (0 to 20.7 bar)
- Proof Pressure: 375 psig (25.9 bar)
- Burst Pressure: 1250 psig (86.2 bar)
- Media: Air, Inert gases, water, light oils
- Media Temperature: -4 to 392°F (-20° to 200°C)
- Ambient Temperature: -4 to 248°F (-20° to 120°C)
- Seal Material: Viton



150BMP-2451B

## 150BMP Solenoid Control Valves

IR Part Number	Thread Size Inlet – Outlet	Voltage (DC)	Weight – lb (kg)	Description
150BMP-1051B*	¼" – ¼"	12 volt	1.95 (.88)	24" (61 cm) Long Wire Leads
150BMP-2451B*	¼" – ¼"	24 volt	1.95 (.88)	24" (61 cm) Long Wire Leads
150BMP-6451*	¼" – ¼"	64 volt	1.95 (.88)	24" (61 cm) Long Wire Leads
150BMP-A1051C*	¼" – ¼"	12 volt	1.95 (.88)	Pioneer Connector Lead

\* Can be mounted on 150BMP-B2451 elbow bracket.

## Dimensions

### Solenoid Control Valve & Bracket

**150BMP-B2451  
Mounting Bracket**  
Weight: .39 lbs (.17 kg)

**Note:** All dimensions shown are for reference only. Specifications subject to change without notice.

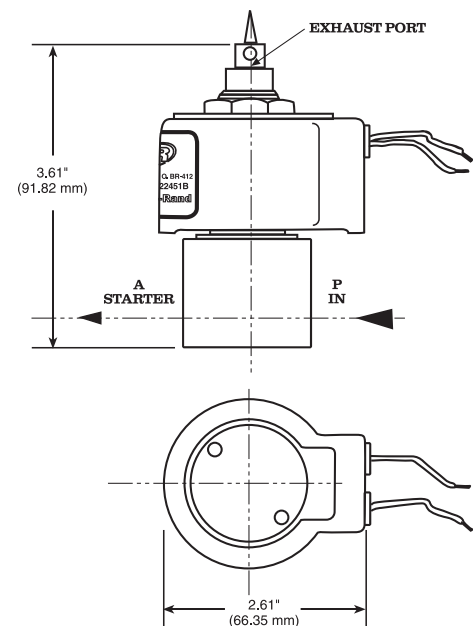
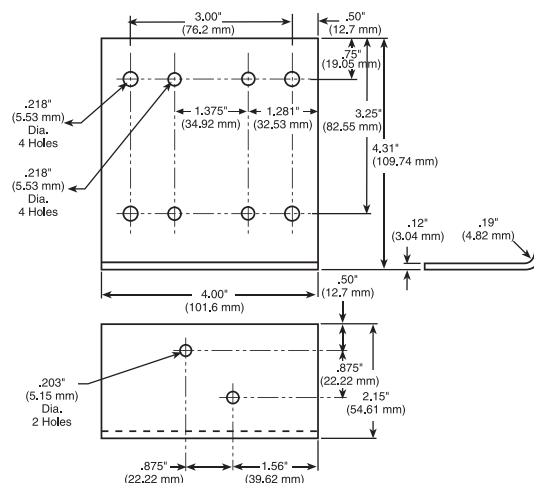

## Specifications

- Rated Operating Pressure: 150 psig
- Rated Operating Voltage: 12-24 VDC
- Rated Current Draw: 750 mA

## ST400 Solenoid Control Valves

IR Part Number	Inlet – Outlet	Weight – lb (kg)	Description
ST400-A339M	1" – 1" Flange Style	4.5 (2.04)	Manual Control Valve; must be coupled to Solenoid or Push Button Valve
ST400-C339	1" – 1" Flange Style	2.96 (1.34)	Relay Valve with Top Mounted Solenoid Valve
ST400-K619	N/A	.30 (.13)	ST400-A339M Repair Kit

## Dimensions

### ST400-A339M

**Note:** All dimensions shown are for reference only. Specifications subject to change without notice.

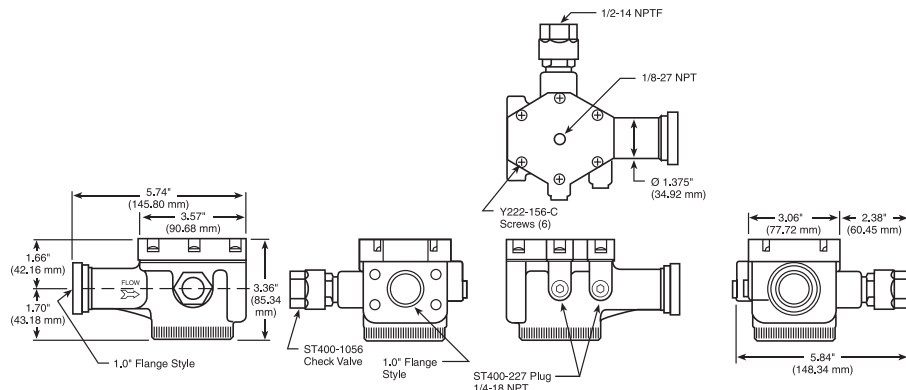

## Dimensions

### ST400-C339

**Note:** All dimensions shown are for reference only. Specifications subject to change without notice.

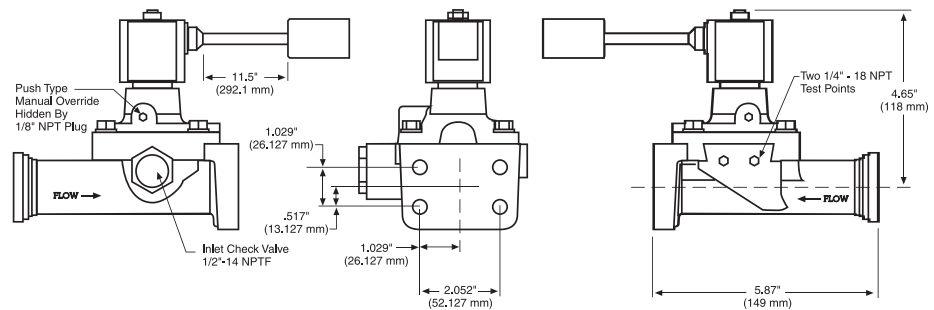

# Push Button Control Valves

The IR manually actuated push button control valve is designed for pilot operation of the IR relay valve. Simple and reliable, this valve readily mounts in a 7/8" diameter hole on dashboards or control panels. The chrome-plated SMB-G618 valve is available for use in marine, offshore and natural gas applications, while the brass bodies SMB-618 valve is suitable for air applications only.

## Specifications

- Operating Temperature Range: -40 to 200°F (-40 to 93.3°C)
- Maximum Operating Pressure: 225 psi (15.5 bar)



SMB-620  
Black Push Button



SMB-618



SMB-G618

## Push Button Control Valves

IR Part Number	NPT Size Inlet – Outlet	Weight – lb (kg)	Description
SMB-618	1/8" – 1/8"	.47 (.21)	Air-approved Push Button Valve
SMB-G618	1/8" – 1/8"	.48 (.21)	Gas-approved Push Button Valve

## Ingersoll Rand Replacement Parts

IR Part Number	NPT Size Inlet – Outlet	Weight – lb (kg)	Description
SMB-619	.25" – 28 UNF	.05 (.02)	IR White Push Button
SMB-620	.25" – 28 UNF	.05 (.02)	Black Push Button

## Dimensions

### SMB-G618

**Note:** All dimensions shown are for reference only. Specifications subject to change without notice.

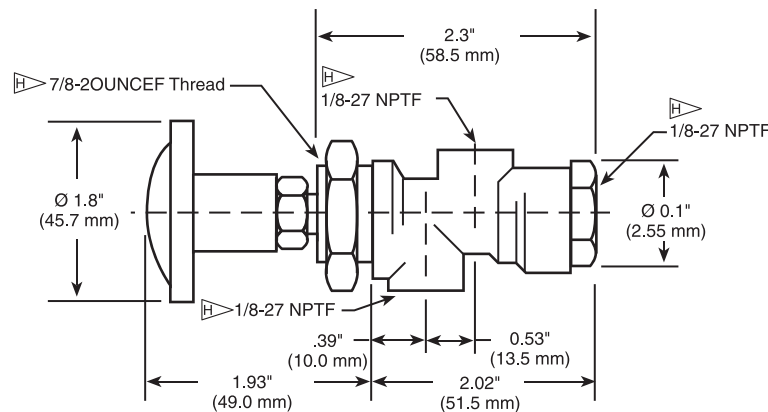

# Air Strainers

IR strainers are used in the air line to assure long starter life where air or gas is contaminated. The ST900 strainer screens the starter air utilizing a 300-mesh element reinforced on two sides by a 20-mesh internal stainless steel screen to ensure air integrity. The ST1000 strainers have stainless steel bodies and utilize 40-mesh stainless steel screens.

## Specifications

- Maximum Working Pressure:

Saturated Steam	Water, Oil, Gas	Compressed Air
250 psi @ 400°F	400 psi @ 150°F	500 psi @ 150°F
15.5 bar @ 204°C	27.6 bar @ 66°C	34.4 bar @ 66°C



ST900-267-16  
Air Strainer



ST900-266-16  
Strainer Element



ST1000-267-24  
ST1000-266-24  
ST1000-267-32  
ST1000-266-32  
Air Strainer  
Strainer Element

## ST900 | ST1000 Air Strainers

IR Part Number	Thread Size Inlet – Outlet (NPT)	Weight – lb (kg)	IR Strainer Element Replacement Part #	Description
ST900-267-16	1" – 1"	3.00 (1.36)	ST900-266-16	3BMG, 5BMG, SS175G Strainer
ST900-267-24	1-1/2" – 1-1/2"	8.00 (3.63)	ST900-266-24	150BM, SS350G, 150T, ST400 Strainer
ST900-267-32	2" – 2"	12.50 (5.67)	ST900-266-32	SS800, ST700, ST900, ST600 Strainer
ST1000-267-24	1-1/2" – 1-1/2"	2.66 (1.21)	ST1000-266-24	150BM, SS350, SS800, ST1000
ST1000-267-32	2" – 2"	3.92 (1.78)	ST1000-266-32	SS800, ST1000

Dimensions

Note: All dimensions shown are for reference only. Specifications subject to change without notice.

IR Part Number	Dim. A in. (mm)	Dim. B in. (mm)	Dim. C in. (mm)
ST900-267-16	4.00 (101.4)	3.25 (82.6)	2.62 (66.5)
ST900-267-24	5.75 (146.1)	5.00 (127.0)	3.87 (98.3)
ST900-267-32	7.00 (177.8)	6.125 (155.6)	4.75 (120.7)
ST1000-267-24	4.72 (120)	5.00 (127.0)	2.99 (76.0)
ST1000-267-32	5.51 (140)	6.125 (155.6)	3.54 (89.9)

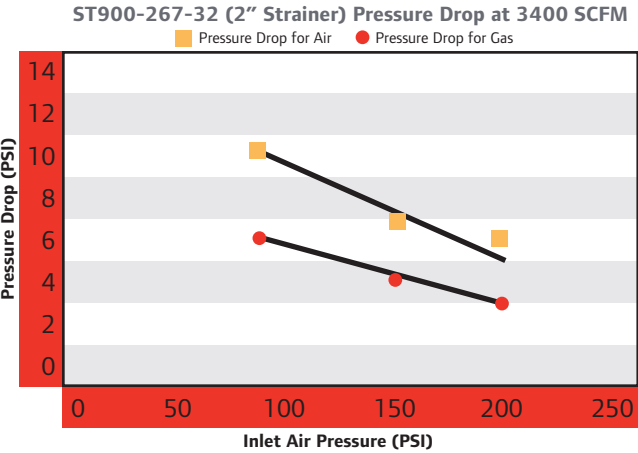
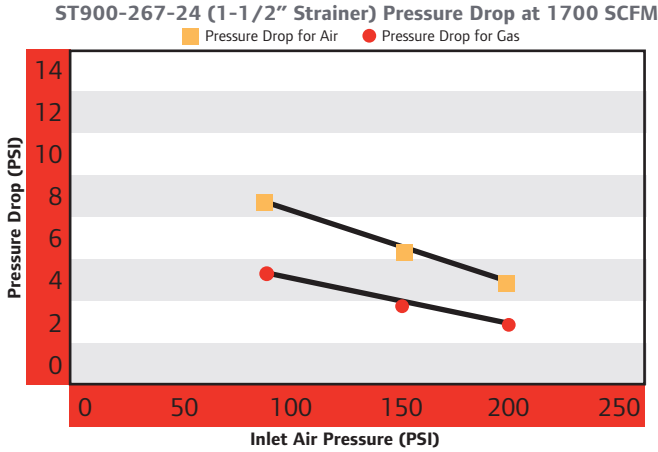
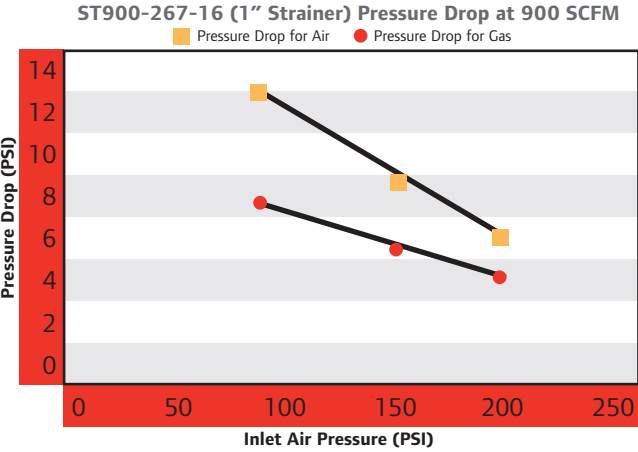
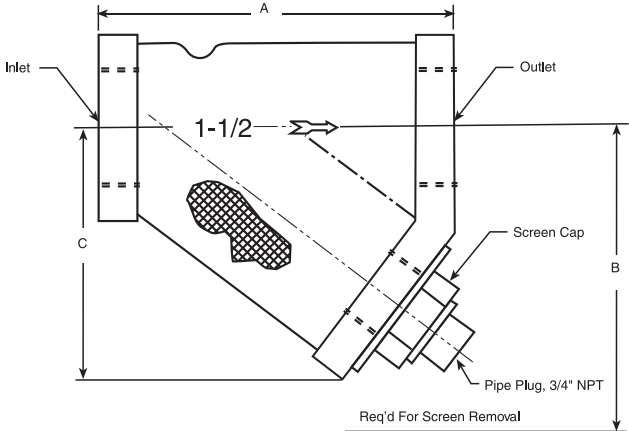

# Mufflers

IR mufflers are designed to effectively limit starting noise levels.

## Specifications

- Low back pressure provides minimal power loss for full starter power
- Effective sound attenuation for low noise level
- Non-freezing for reliable operation
- Self-cleaning to eliminate clogging and ensure longer life while reducing maintenance time
- Capable of direct or remote mounting for flexibility of application

## Dimensions

**Note:** All dimensions shown are for reference only. Specifications subject to change without notice.

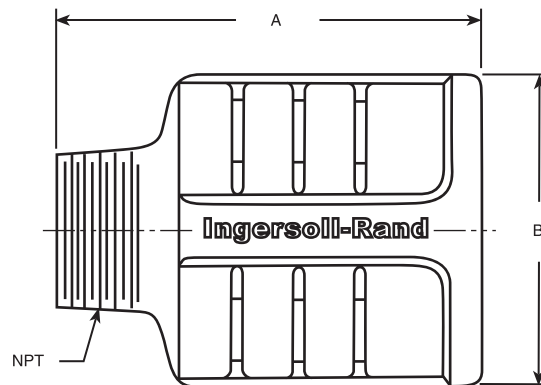

## Mufflers

IR Part Number	NPT Size	Dim. A in. (mm)	Dim. B in. (mm)	Weight – lb (kg)	For Model Series
3BM-WM07	3/4"	7.18 (182.37)	2.22 (56.37)	.83 (0.38)	3BM, 5BM (Older Housing)
3BM-A674	1"	8.66 (219.96)	3.85 (97.79)	1.19 (0.54)	3BM, 5BM (New Housing)
150BM-A674	1-1/4"	4.21 (106.9)	3.34 (84.8)	1.50 (0.68)	150BM, SS175
SS350-A674	1-1/2"	4.56 (115.8)	3.31 (84.1)	1.13 (0.50)	SS350
150T-312	2"	5.50 (139.7)	2.75 (69.85)	1.85 (0.84)	150T, ST500
SS800-A674	2-1/2"	6.66 (169.21)	4.75 (120.77)	3.35 (1.52)	SS800



3BM-WM07



3BM-A674



150BM-A674



SS350-A674



150T-312



SS800-A674



# Regulators

## Rated Operating Conditions

- Inlet Pressure: 10 to 450 psig (0.7 to 31 bar)
- Maximum Outlet Pressure: 250 psig (17.2 bar)
- Temperature: 0° to 175°F (-18° to 79°C)  
- With dewpoint less than air temperature below 35°F (2°C)
- Air Consumption: 2200 scfm @ 150 psi

## Specifications

- Fluid: Compressed Air
- Type: Relieving
- Ports: Main: 1-1/2" or 2" NPT  
Gauge: 1/4" NPT  
Exhaust (relieving models only): 3/4" NPT
- Outlet Pressure Adjustment Range:  
10 to 250 psig (0.7 to 17.2 bar)
- Threads: Use SMB-441 sealant on threads of air line fittings. Apply sealant evenly to threads only. Excessive sealant may interfere with valve operation.



NR-24-8 Pilot Operated Regulator with Integral Pilot

Outlet pressure adjustment ranges are not minimum or maximum outlet pressure limits. Regulators can be adjusted to zero psig outlet pressure and, generally, to pressures in excess of those specified. The use of these regulators to control pressures outside of the specified ranges is not recommended.

## Regulators

IR Part Number	Description
NR-24-8	Pilot Operated Regulator with Integral Pilot (1-1/2" NPT)
NR-24-8-2	Pilot Operated Regulator with Integral Pilot (2" NPT)
NR24-TK1	NR-24-8 Tune Up Kit

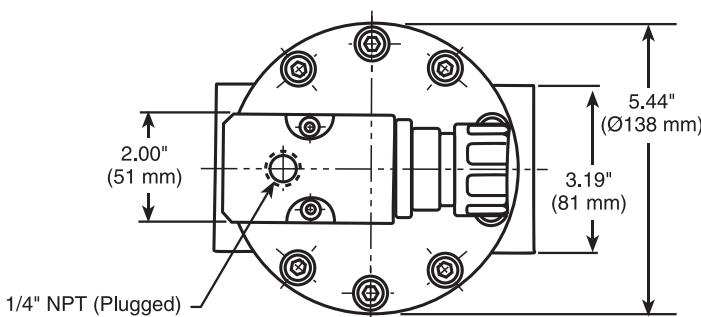

## Dimensions

### NR-24-8

**Note:** All dimensions shown are for reference only. Specifications subject to change without notice.

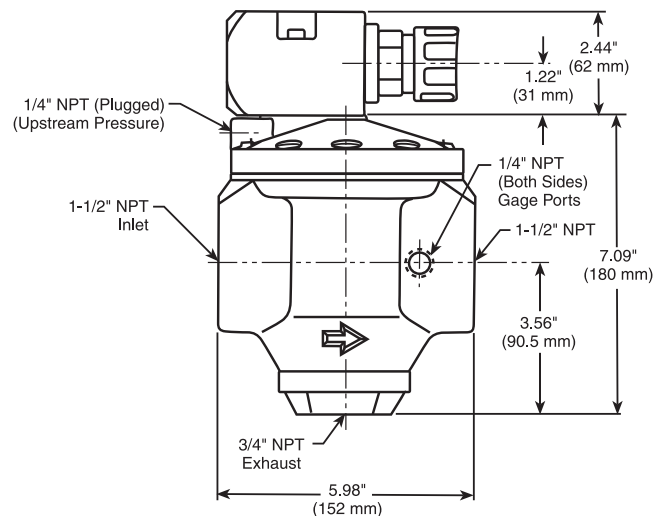

## Installation

1. Install a compressed air filter upstream of regulator.
2. In systems with a cyclic demand, install regulator upstream of cycling control valves.
3. System piping should be same size as regulator ports.
4. Install regulator as close as possible to the device being serviced. Regulator can be installed at any angle.
5. Connect piping to proper ports using pipe thread sealant on male threads only. Do not allow sealant to enter interior of regulator. Air flow must be in same direction as arrow on slave regulator body.
6. If desired, connect an outlet pressure gauge to one of the gauge ports. Gauge ports can also be used as additional outlets. Plug unused gauge ports.
7. To reduce noise and protect internal ports, install a muffler (part number M8006A) in the exhaust port (marked "EXH") of relieving type regulators.

## Adjustment

1. Before turning on system pressure, turn pilot regulator adjusting knob counterclockwise until all load is removed from regulating spring.
2. Turn on system pressure.
3. Turn pilot regulator, adjusting knob clockwise until the desired outlet pressure is reached.
4. To avoid minor readjustment after making a change in pressure setting, always approach the desired pressure from a lower pressure. When reducing from a higher to a lower setting, first reduce to some pressure less than that desired, then bring up to the desired pressure.
5. Push adjusting knob downward to lock pressure setting. To release, pull knob upward.

### Warning

These regulators are intended for use in industrial compressed air systems only.

Do not use these regulators where pressure or temperature can exceed rated operating conditions.

If outlet pressure in excess of the regulator pressure setting could cause downstream equipment to rupture or malfunction, install a pressure relief device downstream of the regulator. The relief pressure and flow capacity of the relief device must satisfy system requirements.

The accuracy of the indication of pressure gauges can change, both during shipment (despite care in packaging) and during the service life. If a pressure gauge is to be used with these products and if inaccurate indications may be hazardous to personal property, the gauge should be calibrated before initial installation and at regular intervals during use. For gauge standards refer to ANSI 840, 1-1974.

These products are not designed for use with fluids other than air, for nonindustrial applications, or for life support systems.

### Installation Warning

Do not plug exhaust port in bottom plug of relieving type regulators, as the relief feature will become inoperative.

# In-Line Lubricators

## Specifications

- Reservoir: 1/2 Pint Metal
- Maximum Operating Temperature = 175 °F (79 °C)
- Maximum Operating Pressure = 250 psi (17.2 bar)
- $C_v = 26$
- Media: Air, clean natural gas (see circular letter A-1077)
- Recommended Operating Flow Range at 100 psig (6.9 bar): 160 to 600 scfm (78 to 283 dm<sup>3</sup>/s)
- Recommended Lubricants: This lubricator will perform satisfactorily using misting type oils rated 150 to 200 SSU (Saybolt seconds) @ 110 °F (38 °C)
- Material Construction: Body = Aluminum  
Reservoir = Steel  
Sight-Feed Dome = Pyrex & Aluminum  
Elastomers = Neoprene & Buna-N



NL-8-8



NL-24-8

## Installation

- Air line piping should be same size as lubricator ports.
- Install lubricator vertically (sight-feed dome up) in air line downstream of filter and regulator as near as possible to the device being served. This lubricator may be installed upstream or downstream of directional control valves.
- Connect piping to proper ports using pipe thread sealant on male threads only. Do not allow sealant to enter interior of lubricator. Air flow must be in direction of arrow on side of body.
- Remove fill plug and fill reservoir with a good quality lubricant to 3/4" below bottom of threads on dipstick. Do not overfill.

## Adjustment

- Adjust drip rate only when there is a constant rate of flow through the lubricator.
- Determine the average rate of air flow (scfm) through the lubricator, then adjust the needle valve using a 3/32" Allen Wrench to obtain the recommended drip rate (Drops/min). Turn needle valve counterclockwise to increase and clockwise to decrease the drip rate.
- Monitor the device being lubricated for a few days following initial adjustment. Readjust the drip rate if the oil delivery at the device appears either excessive or low.

### Warning

These units must not be used where pressure or temperature may exceed maximum rated operating conditions. See specifications.

In lubrication applications, some oil mist may escape from the point of use into the surrounding atmosphere. Users are referred to OSHA safety and health standards for limiting oil mist contamination and utilization of protecting equipment.

## In-Line Lubricators

IR Part Number	Port Thread Size NPT Inlet – Outlet	Weight lb (kg)
NL-8-8	1/2" – 1/2"	1.70 (.77)
NL-24-8	1-1/2" – 1-1/2"	2.70 (1.22)
NL24-TK1	N/A	.05 (.02)

## Dimensions

### NL-8-8

**Note:** All dimensions shown are for reference only. Specifications subject to change without notice.

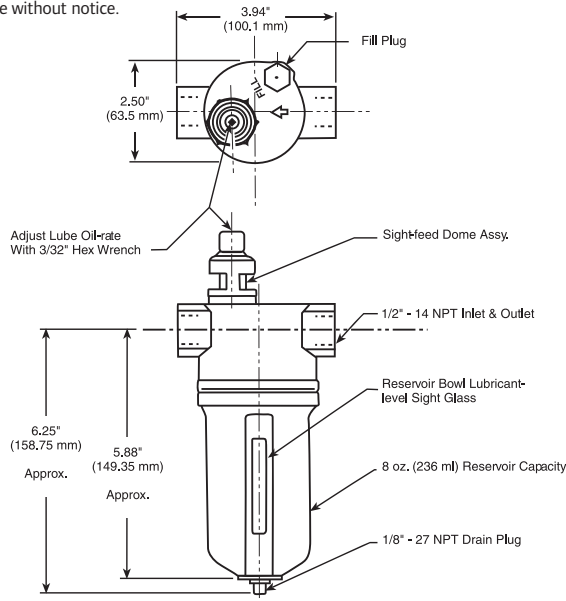

## Dimensions

### NL-24-8

**Note:** All dimensions shown are for reference only. Specifications subject to change without notice.

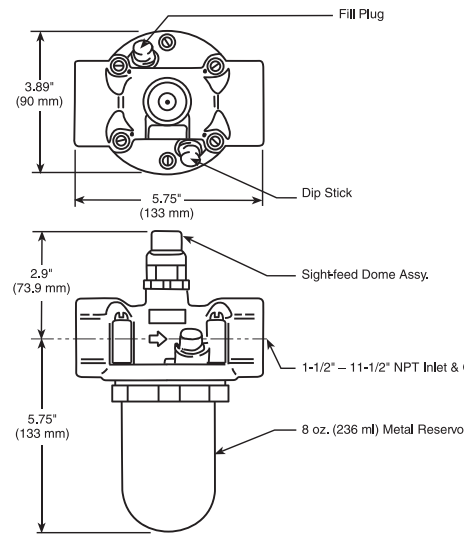

## Recommended Drip Rate

Recommended Drip Rate Settings for Average Lubrication

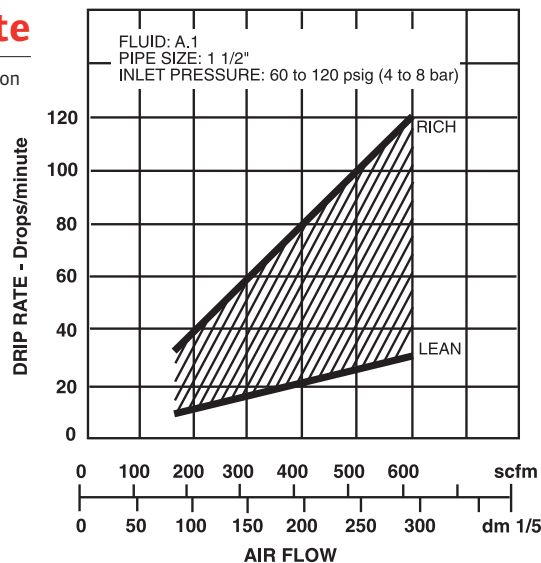
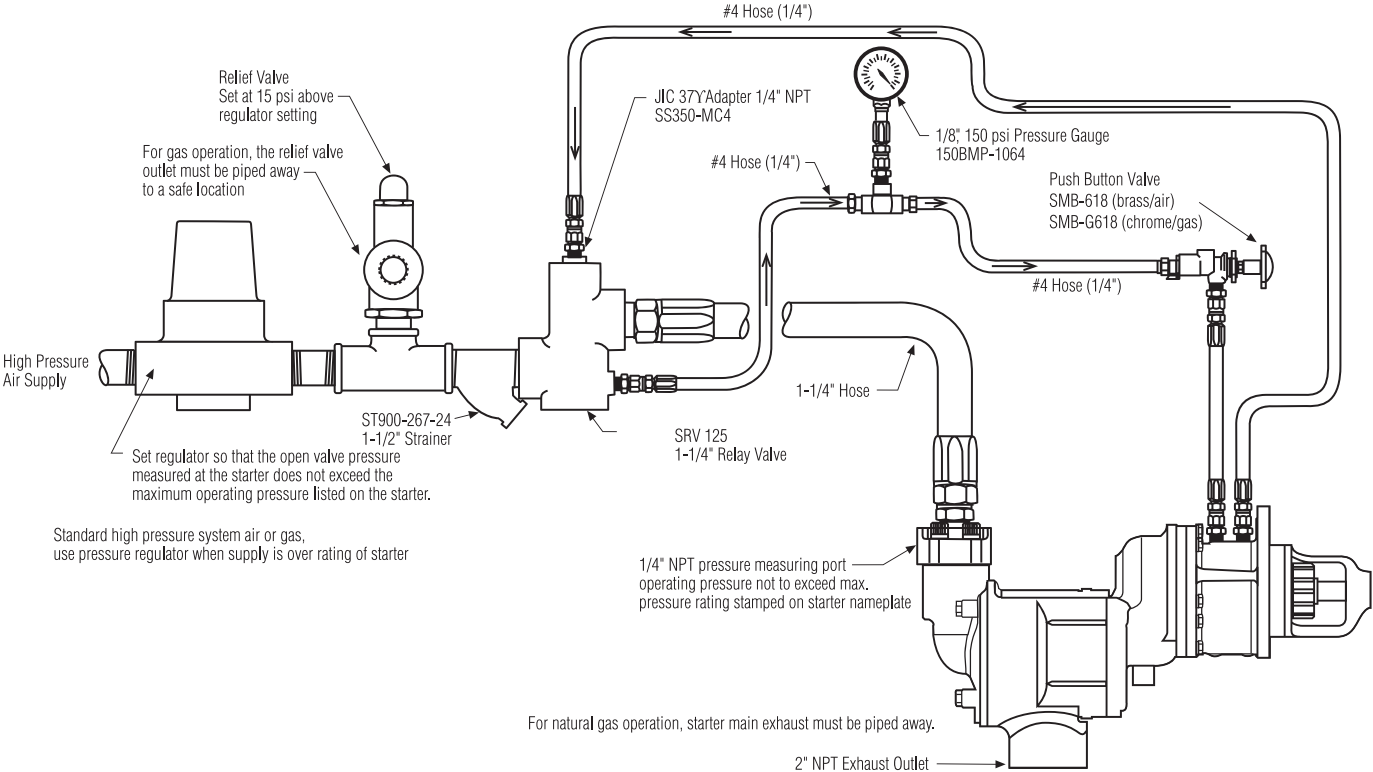

FIGURE 1 Recommended Drip Rate Settings for Average Lubrication

# Installations

## 150 & ST500 Stationary - Gas



## ST400 Installation

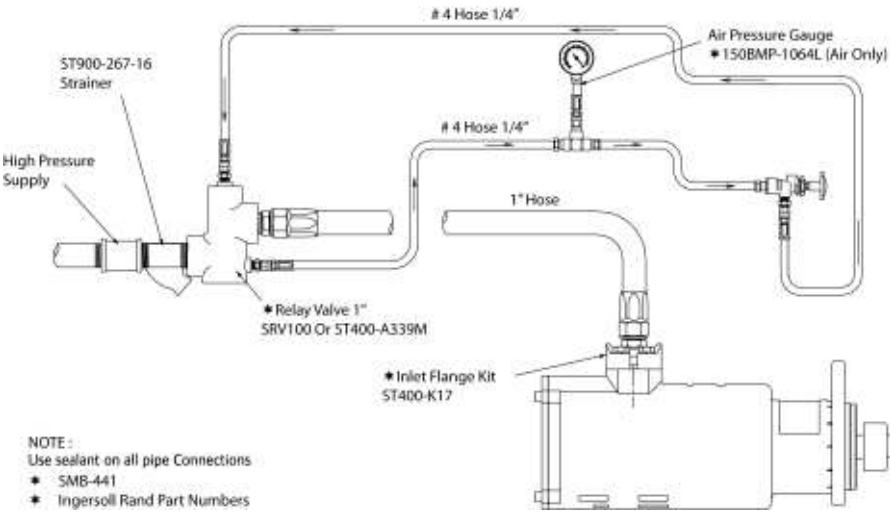

### ST600/ST700/ST900/ST1000 Inertia Installation

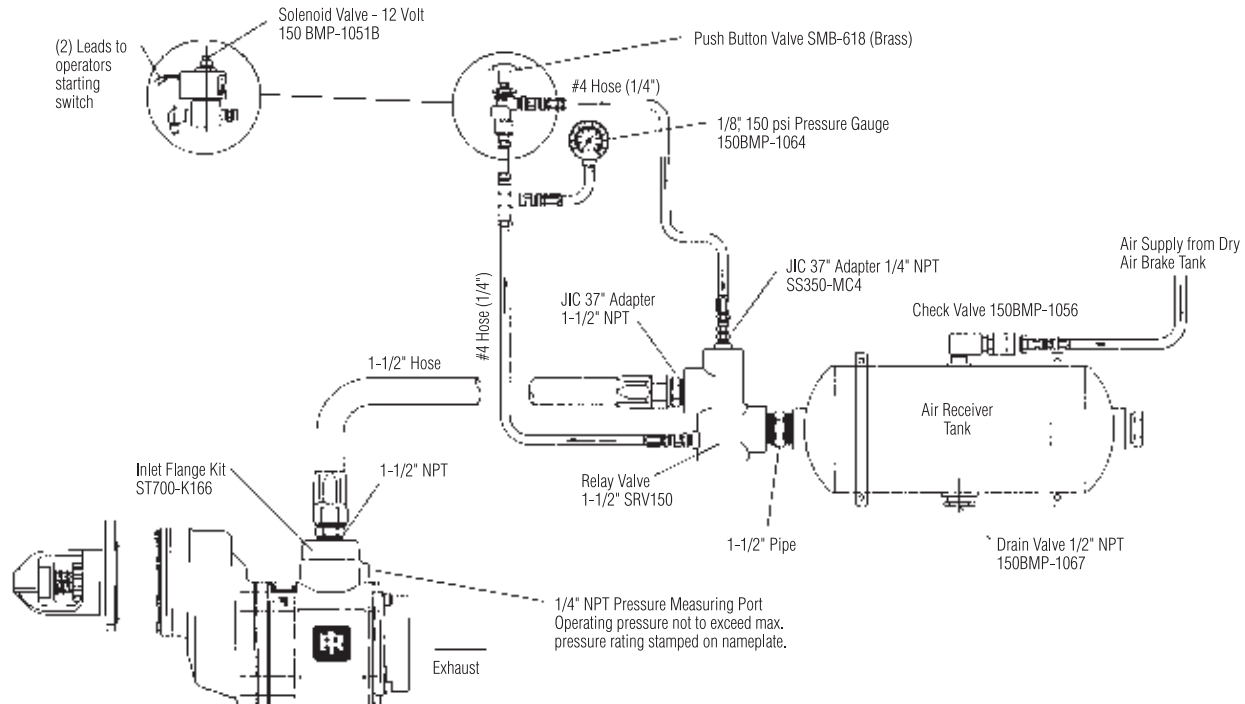

### ST700/ST900/ST1000 Typical Stationary Installation

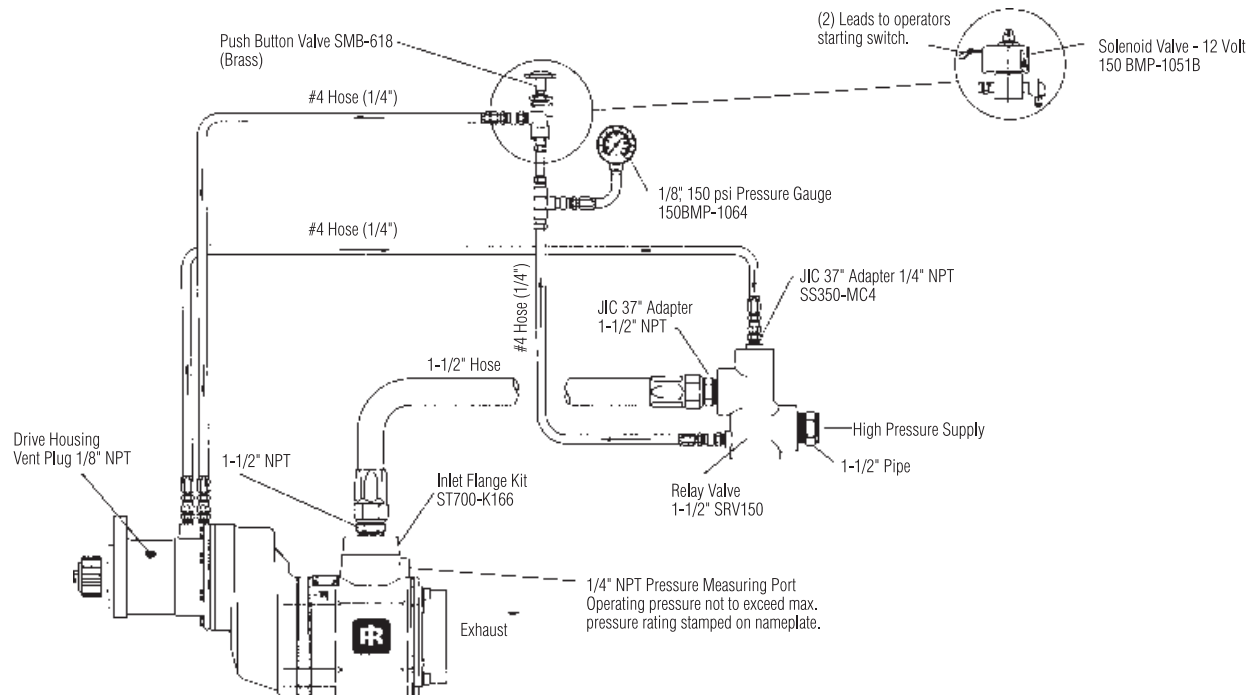

# ST700/ST900/ST1000 Typical Multiple Starter Application Installation

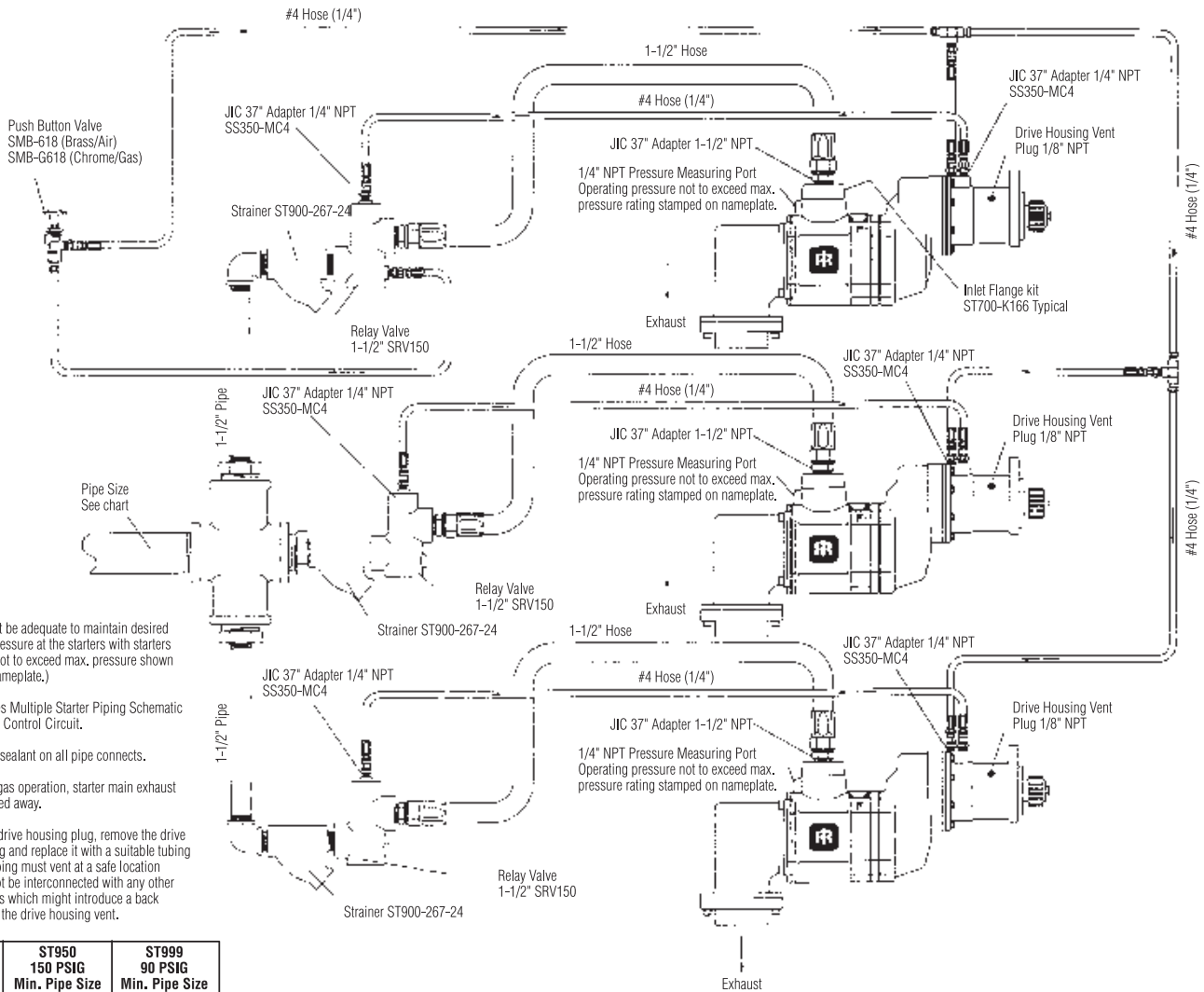

Supply must be adequate to maintain desired operating pressure at the starters with starters running. (Not to exceed max. pressure shown on starter nameplate.)

ST900 Series Multiple Starter Piping Schematic showing the Control Circuit.

NOTE: Use sealant on all pipe connects.

For natural gas operation, starter main exhaust must be piped away.

To pipe the drive housing plug, remove the drive housing plug and replace it with a suitable tubing line. The tubing must vent at a safe location and must not be interconnected with any other exhaust lines which might introduce a back pressure on the drive housing vent.

No. of Starters	ST950 150 PSIG Min. Pipe Size	ST999 90 PSIG Min. Pipe Size
2	2-1/2"	3"
3	3"	3-1/2"
4	3-1/2"	4"
5	3-1/2"	4"

## 150BMP and SS100 Typical Installations

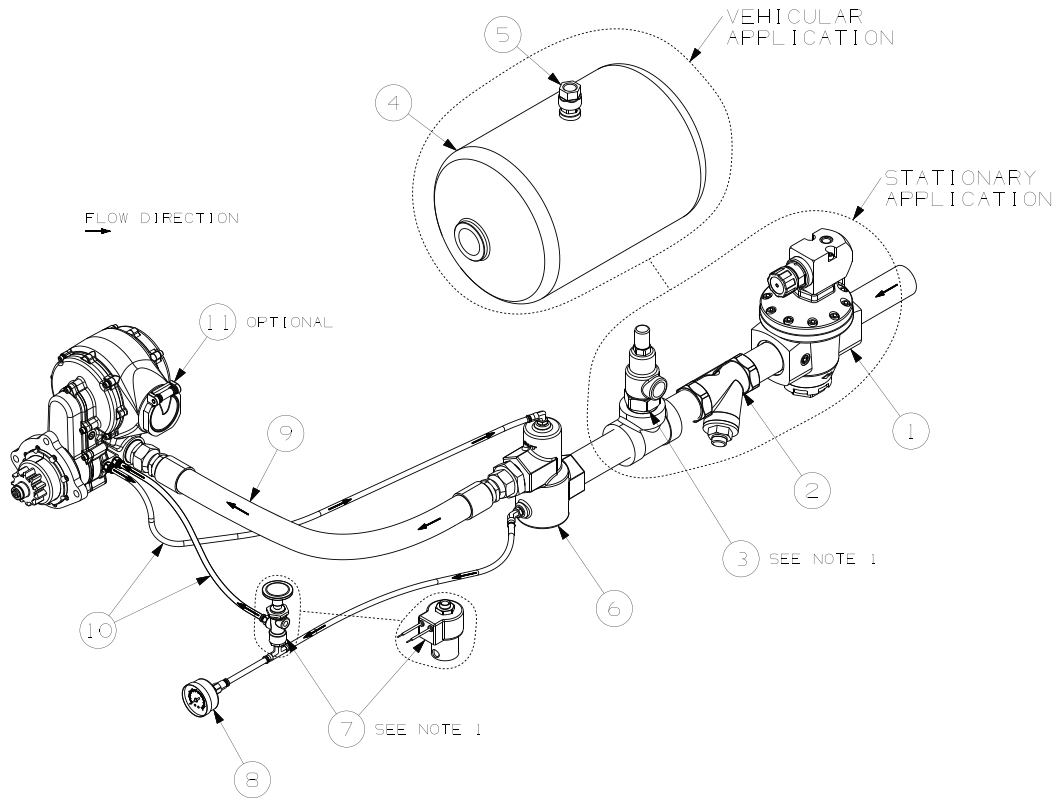

## SS350/150MPE Stationary Installation

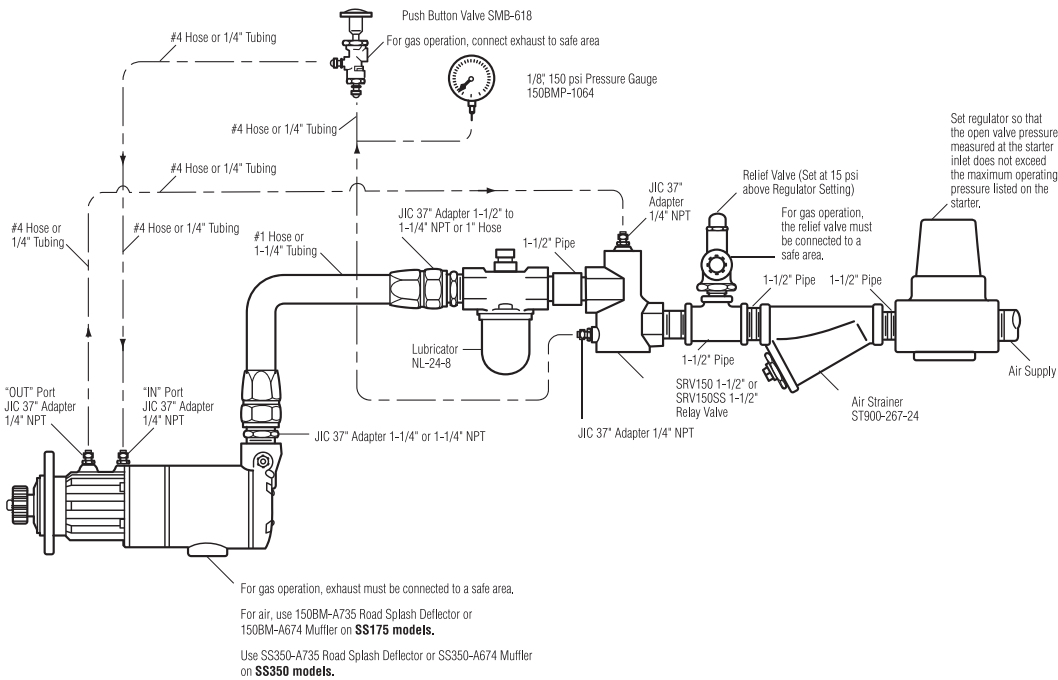



### SS350/150BMPE Typical Vehicular Installation

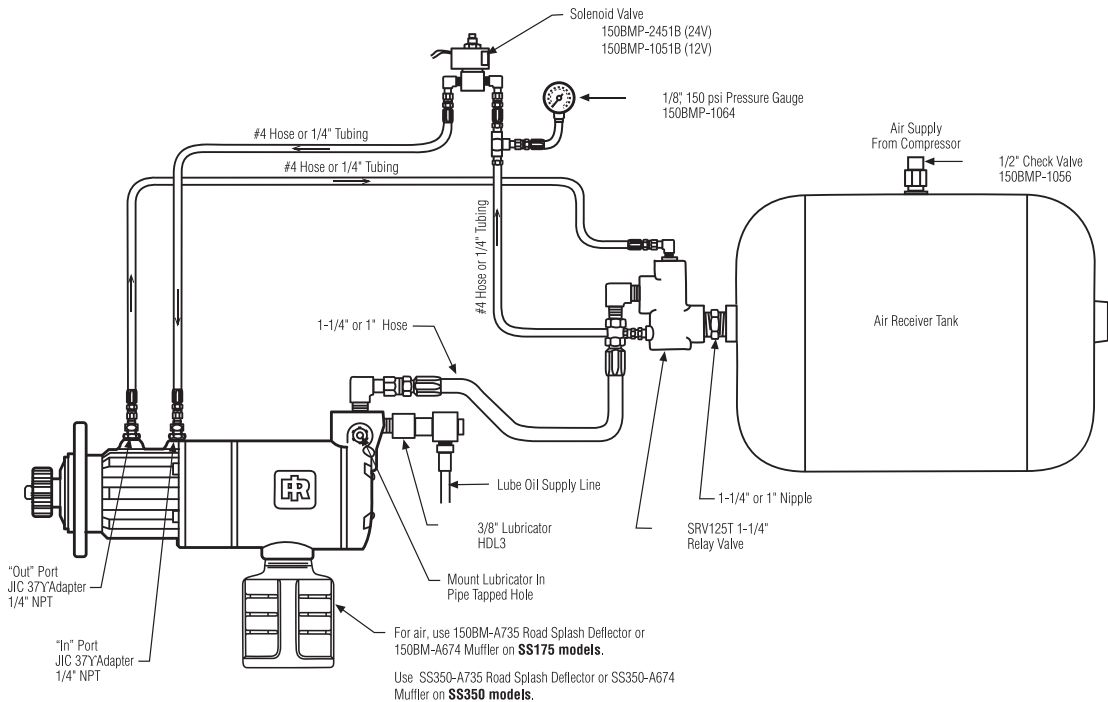

### 150BMG (Gas) Stationary Installation

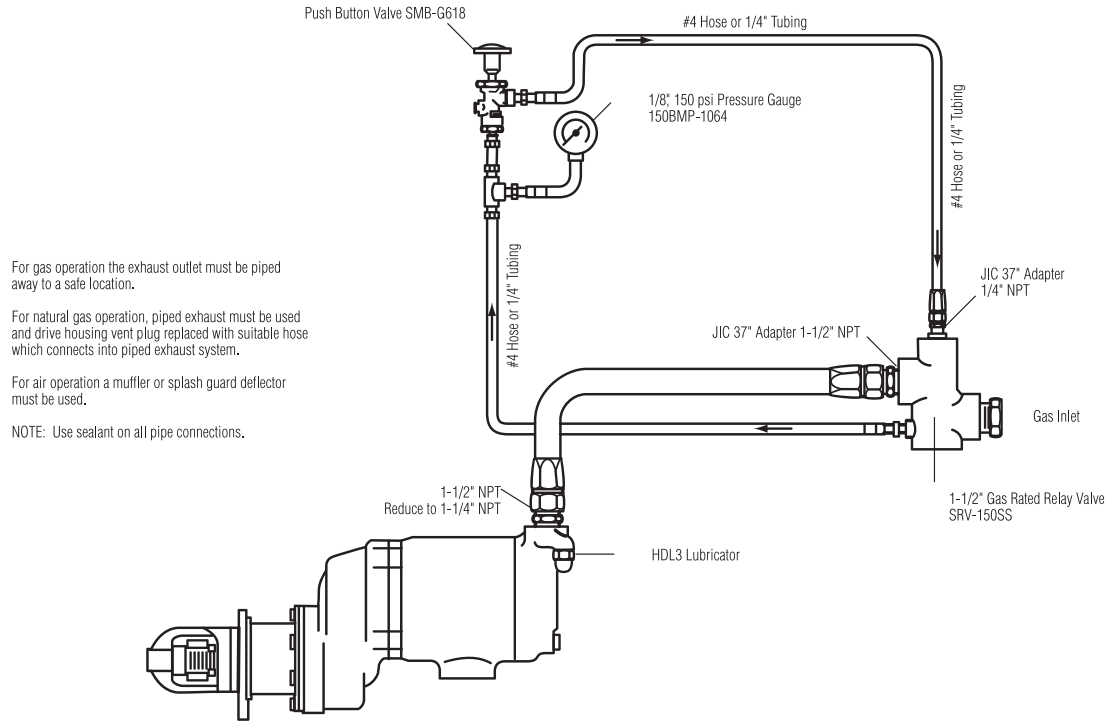

For gas operation the exhaust outlet must be piped away to a safe location.

For natural gas operation, piped exhaust must be used and drive housing vent plug replaced with suitable hose which connects into piped exhaust system.

For air operation a muffler or splash guard deflector must be used.

NOTE: Use sealant on all pipe connections.

## SS810 Typical Stationary Installation

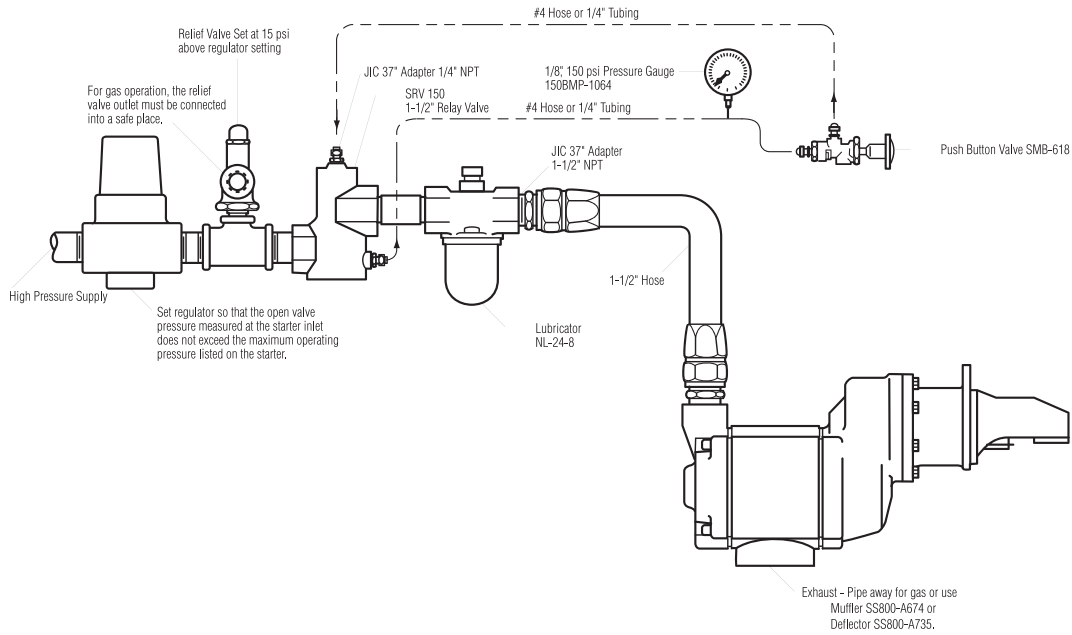

## SS815/SS825/SS850 Typical Stationary Installation

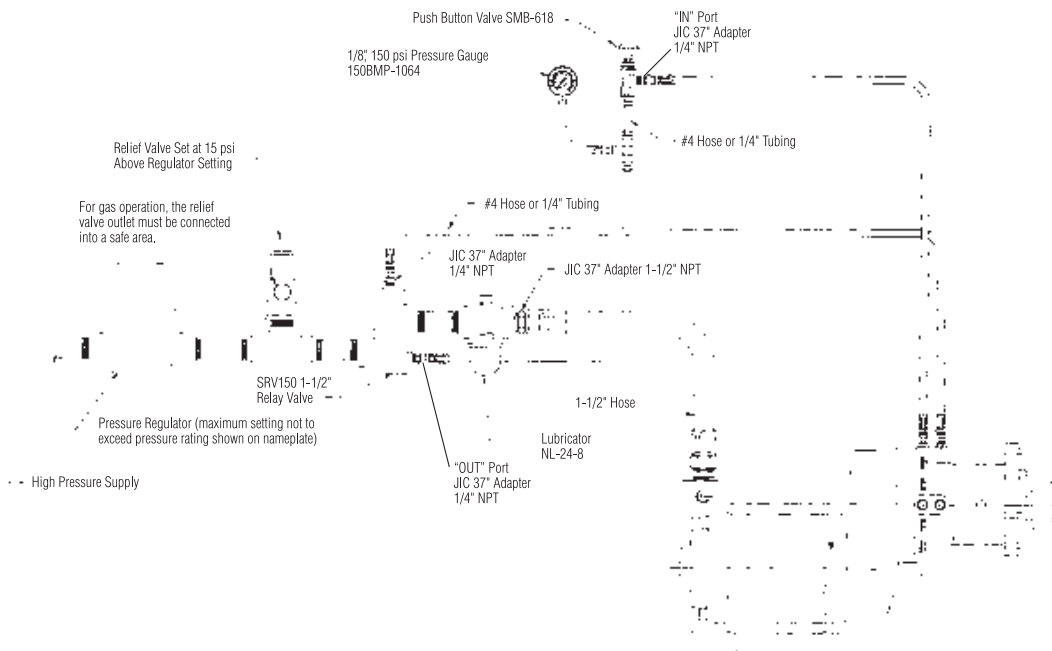

## Locations

### Americas

#### United States

IR ESS Customer Service/  
Distribution Center  
800 Beatty Street  
Davidson, NC 28036  
United States  
Phone: (888) START-AIR (782-7824)  
Fax: (615) 672-0801

#### Canada

Marketing/Sales/Service Headquarters  
Ingersoll Rand Canada Inc.  
51 Worcestor Road  
Toronto, Ontario M9W 4K2  
Canada  
Phone: (416) 213-4500  
Fax: (416) 213-4500

#### Brazil

Ingersoll Rand do Brasil  
Al. Caiapós, 311 – Tamboré  
CEP: 06460-110  
Barueri, Sao Paulo  
Brasil  
Phone: (55) 11.2109.8900  
Fax: (55) 11.2109.8999

#### Chile

Ingersoll Rand Industrial Technologies  
Av. Americo Vespucio 2512,  
Conchalí, Santiago  
Chile  
Phone: +562.2485 8356

#### Colombia

Ingersoll Rand  
Autopista Norte # 108-27  
Piso 18 Torre 2 Centro Empresarial  
Edificio Paralelo 108  
Bogotá  
Colombia  
Phone: +57 1 651 7272

#### Mexico

Ingersoll Rand, S.A. de C.V.  
Blvd. Centro Industrial No. 11  
Col. Industrial Puente de Vigas.  
54070  
Tlanepantla, Edo. de Mexico  
Mexico  
Phone: 01.800.561.4192  
Fax: 55.53904031

#### Perú

Centro Empresarial El Trigal  
Calle los Antares 320  
Torre A Oficina 908  
Santiago de Surco, Lima 33  
Perú  
Phone: +511.712.4316

### Europe / Africa / Middle East

#### Czech Republic

Ingersoll Rand - Regional Office  
Florianova 2460  
Hostivice  
253 01  
Phone: +420 (257) 109 756  
Fax: +420 (257) 109 758  
ingersollrandeasterneurope@irco.com

#### England (UK)

Ingersoll Rand - Customer Centre  
Unit 10, Brunswick Industrial Centre  
Brunswick Road  
Ashford, Kent  
TN23 1EH

#### Germany

Ingersoll Rand - Regional Office  
Max-Planck-Ring 27  
Oberhausen  
46049  
Phone: +49 (208) 9994 250  
Fax: +49 (208) 9444 252  
ingersollrandgermany@irco.com

#### Italy

Strada Provinciale Cassanese, 108  
Vignate  
Milano  
20060  
Phone: +39 (02) 95056 1  
Fax: +39 (02) 9560 415  
ingersollranditaly@irco.com  
tuttoperlaria@eu.irco.com

#### Netherlands

Ingersoll Rand - Regional Office  
Produktieweg 10  
Zoeterwoude  
2382 PB  
Phone: +31 (71) 582 3456  
Fax: +31 (71) 582 3400  
info@ingersollrand.nl

#### Poland

Ingersoll Rand - Regional Office  
Kolejowa 5/7  
Warszawa  
01-217  
Phone: +48 (22) 434 77 00  
Fax: +48 (22) 434 77 01  
ingersollrandeasterneurope@irco.com

#### Russia

Ingersoll Rand - Regional Office  
5, 1st Derbenevskiy Lane  
Moscow  
115114  
Phone: +7 (495) 663 8267  
Fax: +7 (495) 785 2126  
ingersollrandcis@irco.com

#### South Africa

Ingersoll Rand - Customer Centre  
Montreal Drive, Airport Industria  
Cape Town  
ingersollrandsa@irco.com

#### Spain

Ingersoll Rand - Regional Office  
Sant Josep, 140-142 - P.I. El Pla  
Sant Feliu de Llobregat  
Barcelona  
08980  
Phone: +34 (93) 457 83 48  
+34 (93) 620 20 71  
Fax: +34 (93) 207 10 38  
ingersollrandspain@irco.com

#### Sweden

Ingersoll Rand - Customer Centre  
Scandinavian Operations - Tore Dahl  
Krossverksgatan 5L  
Malmö  
S-216 16

### Asia / Pacific

#### Australia

Ingersoll Rand Australia  
45-47 Ventura Place  
Dandenong South, Victoria  
3175  
Phone: +61 3 87874343  
Fax: +61 3 87875510

#### Japan

Ingersoll Rand ITS Japan Ltd.  
Honda Denki Bldg.  
5F, 4-5-37, Kami-Ohsaki,  
Shinagawa-ku, Tokyo,  
141-0021  
Japan  
Phone: 81-3-6910-6613  
Fax: 81-3-6910-6631

#### Korea

Ingersoll Rand Korea  
10FL Trutec Building, B6-2 Bloc,  
DMC Lot  
Sangam-dong, Mapo-gu,  
Seoul, 121-270, Korea

#### Shanghai

Ingersoll Rand Machinery  
(Shanghai) Co  
11F, Tower B, City Center of Shanghai  
100 Zunyi Road, Shanghai  
200051  
P.R.China  
Phone: +86 21 2208 1288  
Fax: +86 21 6438 5113

#### Singapore

Ingersoll Rand  
South East Asia (Pte) Ltd  
42 Benoi Road, Singapore  
629903  
Phone: +(65) 6861 1555  
Fax: +(65) 6862 1373



Ingersoll Rand (NYSE:IR) advances the quality of life by creating and sustaining safe, comfortable and efficient environments. Our people and our family of brands—including Club Car®, Ingersoll Rand®, Schlage®, Thermo King® and Trane®—work together to enhance the quality and comfort of air in homes and buildings; transport and protect food and perishables; secure homes and commercial properties; and increase industrial productivity and efficiency. Ingersoll Rand products range from complete compressed air systems, tools and material and fluid handling systems. The diverse and innovative products, services and solutions enhance our customers' energy efficiency, productivity and operations. Ingersoll Rand is a \$14 billion global business committed to a world of sustainable progress and enduring results. For more information, visit [ingersollrand.com](http://ingersollrand.com) or [ingersollrandproducts.com](http://ingersollrandproducts.com).



[www.ingersollrandproducts.com](http://www.ingersollrandproducts.com)

Distributed by:



Ingersoll Rand, IR and the IR logo are trademarks of Ingersoll Rand, its subsidiaries and/or affiliates. All other trademarks are the property of their respective owners. Nothing contained on these pages is intended to extend any warranty or representation, expressed or implied, regarding the product described herein. Any such warranties or other terms and conditions of sale of products shall be in accordance with Ingersoll Rand's standard terms and conditions of sale for such products, which are available upon request.

Product improvement is a continuing goal at Ingersoll Rand. Designs and specifications are subject to change without notice or obligation.

We are committed to using environmentally conscious print practices.

© 2012 Ingersoll Rand IRITS-0611-031