

*Desoutter*



**Industrial**Tools



## *Auto Feed Drills & Tappers*

- *Comprehensive range*
- *Single spindle operations*
- *Multi-spindle processes*

**More Than Productivity**

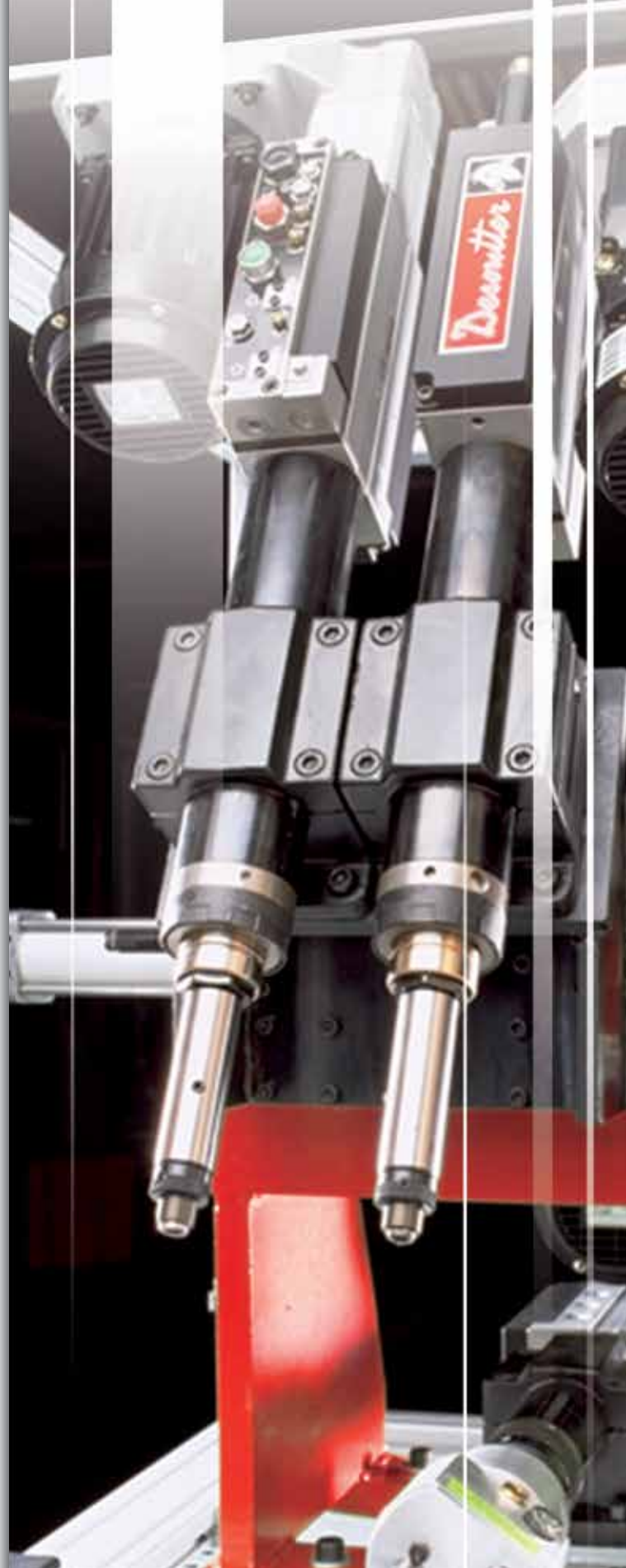

# AFD Applications

---

## Ease of Integration into Machine or Process

- Extensive range of mounting clamps
- Control interfaces to link AFD(E) to other equipment through pneumatics or electrically
- Single signal required for AFD(E) to perform cycle
- Output signals at datum and depth
- Electric motor mounting on 200, 400 and 600 series can be rotated 180°

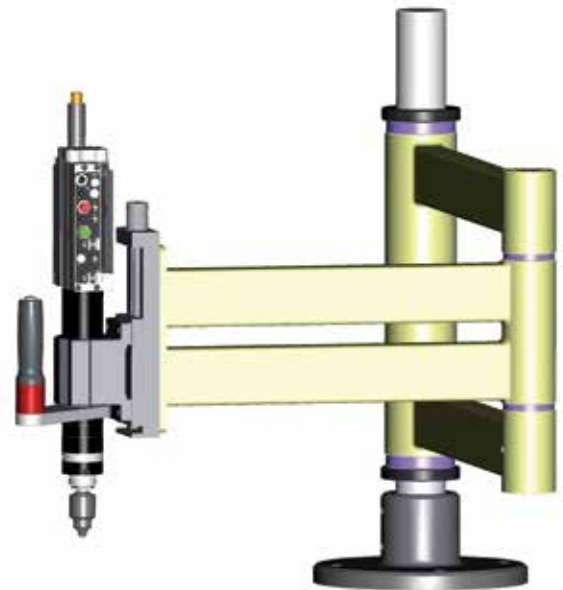

## Comprehensive range of Product

- For single spindle operations to multi spindle processes
- Pneumatic and electric drive from 0.22 to 1.1kW (0.3 to 1.47hp) with thrusts from 1735N (390lbf)
- Reliability through quality

## Modular Design

- Flexibility of unit function and speed
- Common components in different models reduce inventory
- Multiple spindle head options
- Drilling and tapping options for all models



## Auto Feed Drills & Tappers

Auto Feed Drills & Tappers Features .....	4
How to select your AFD .....	5-7

### DRILLING

<b>AFDE200 - AFDE230 (Electric drive)</b> .....	<b>8-9</b>
0.25 kW (0.34hp) - 850 to 11950 rpm	
<b>AFD205 - AFD215 (Pneumatic drive)</b> .....	<b>10-11</b>
0.22 kW (0.30hp) - 650 to 18700 rpm	
<b>AFDE400 - AFDE430 - AFDE410 - AFDE440 (Electric drive)</b> .....	<b>12-13</b>
0.33 - 0.75 kW (0.44 - 1hp) - 330 to 11950 rpm	
<b>AFD415 (Pneumatic drive)</b> .....	<b>14-15</b>
0.38 kW (0.5hp) - 490 to 18000 rpm	
<b>AFDE610 - AFDE620 - AFDE640 (Electric drive)</b> .....	<b>16-17</b>
0.75 - 1.1 kW (1 - 1.47hp) - 330 to 6300 rpm	
<b>AFD684 (Pneumatic drive)</b> .....	<b>18-19</b>
0.61 kW (0.82hp) - 60 to 3300 rpm	

### TAPPING

<b>AFTE480 (Electric drive)</b> .....	<b>20-21</b>
0.75 kW (1hp) - 180 to 1740 rpm	

### ACCESSORIES .....

22-32

Control Block & Interfaces .....	22
AFD Control Options .....	23
Output Spindles - Chucks .....	24-25
Multiple Spindle Heads .....	26-27
Collets .....	28
Clamps .....	29-32
AFD Selection Program .....	35



# Auto Feed Drills & Tappers Features

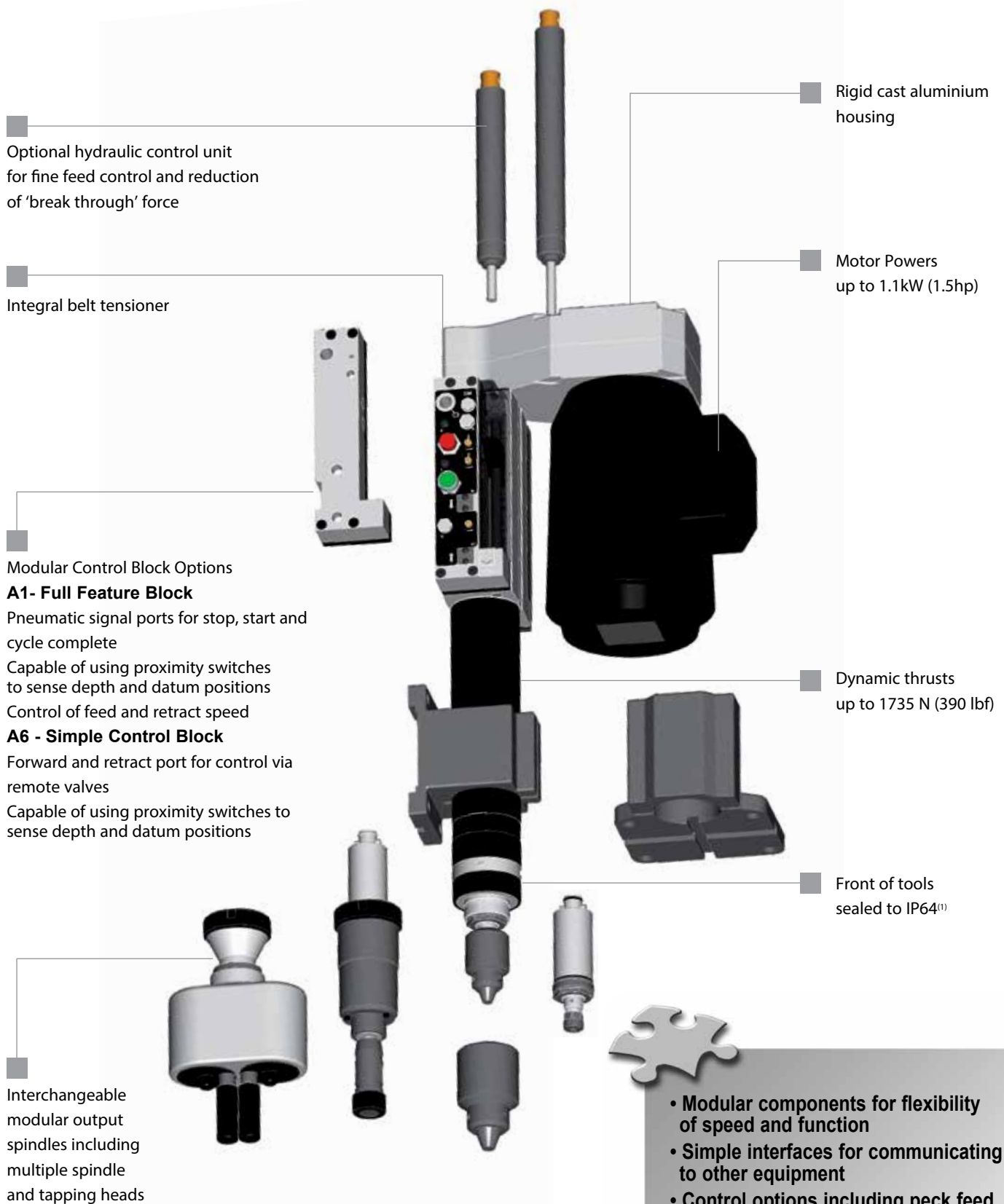

# How to select your AFD

How to Order :

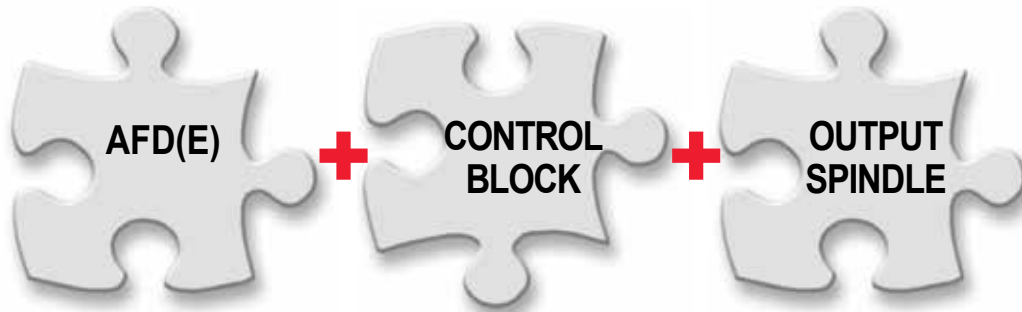

## Model Type

### Pneumatic Feed and Drive

AFD205 0.22kW (0.30hp)  
AFD215 0.22kW (0.30hp)  
AFD415 0.38kW (0.51hp)  
AFD684 0.61kW (0.82hp)

### Pneumatic Feed, Electric Drive

AFDE200 0.25kW (0.34hp)  
AFDE400 0.33kW (0.44hp)  
AFDE410 0.75kW (1.00hp)  
AFDE610 0.75kW (1.00hp)  
AFDE620 1.10kW (1.50hp)

### Electric Feed and Drive via Leadscrew

AFTE480 0.75kW (1.00hp)

## Control Block (see page 22)

A1 – Full feature type<sup>(1)</sup>  
– Automatic cycle  
A6 – Simple type<sup>(1)</sup>  
– Remote cycle control  
A7 – Leadscrew type – PNP  
A8 – Leadscrew type – NPN

## Output Spindle (see page 24 to 28)

### Code Output type

- Chuck  
- Collets  
- Multi Head  
- Tapper

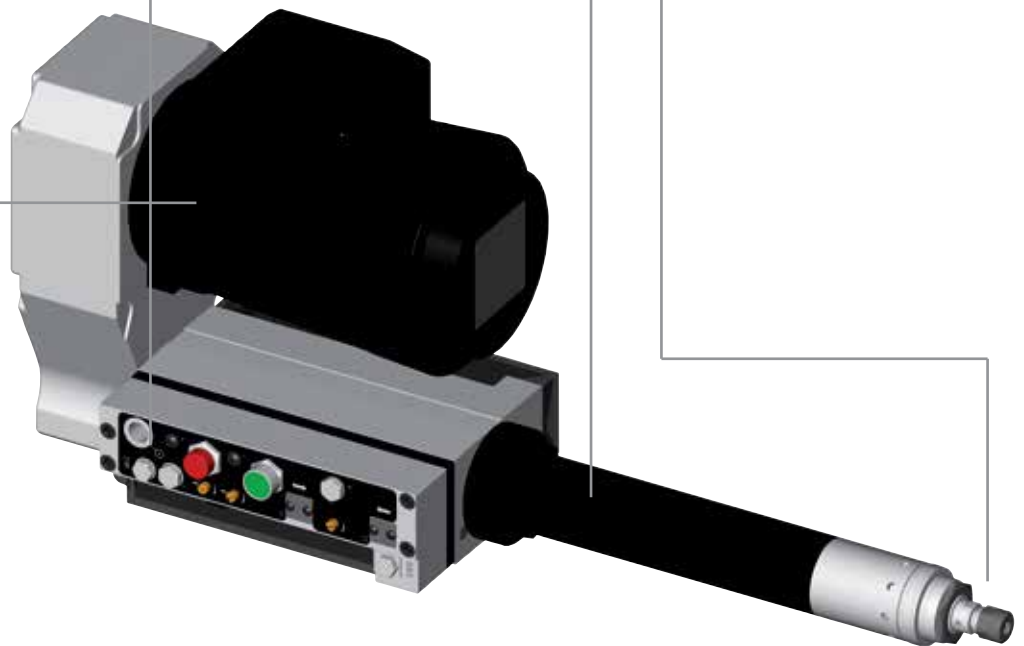

**OPTIONAL**

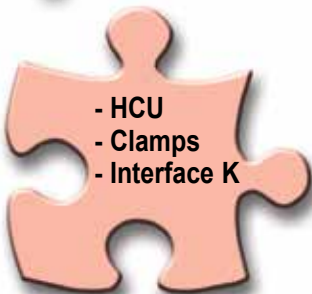

- HCU  
- Clamps  
- Interface K

(see page 23 to 32)

(1) Not required on AFTE models.

# How to select your AFD

## ■ Electric drive - Pneumatic feed

TYPE AND SPEED	FREE SPEED		MAXIUM STROKE		DYNAMIC THRUST		MILD STEEL	ALUMINIUM	HARD WOOD				
	50Hz	60Hz	mm	in.	N	lbf							
<b>AFDE200 Serie - 0.25 kW (0.34hp)</b>							<b>Ø mm</b>	<b>Ø mm</b>	<b>Ø mm</b>				
AFDE200-850	850	1020	90	3.54	320	72	4	5	7				
AFDE200-1200	1200	1450					4	5	6				
AFDE200-2350	2350	2820					3.5	4	5				
AFDE200-2850	2820	3400					2.5	3	4				
AFDE200-3750	3750	4500					2	2.5	2.5				
AFDE200-4600	4600	5450					2	2	2				
AFDE200-5250	5250	6300					1.5	2	2				
AFDE200-8000	8000	9600					1	1.5	1.5				
AFDE200-10000	10000	11950					0.5	1	1				
<b>AFDE400 Serie - 0.33 - 0.37 kW (0.44 - 0.49hp)</b>							<b>Ø mm</b>	<b>Ø mm</b>	<b>Ø mm</b>				
AFDE400-330	330	400	100	3.94	724	163	10	12	16				
AFDE400-550	550	660					9.5	11	16				
AFDE400-900	900	1100					9	10.5	15				
AFDE400-1200	1200	1450					8	10	14				
AFDE400-1450	1450	1740					6	10	12				
AFDE400-1750	1750	2100					5	9	11				
AFDE400-2350	2350	2820					4	8	10				
AFDE400-2850	2850	3400					3	6	8				
AFDE400-3750	3750	4500					2.5	5	6				
AFDE400-4600	4600	5450					2	4.5	5.5				
AFDE400-5250	5250	6300					1.5	4	5				
AFDE400-8000	8000	9600					1	3.5	2.5				
AFDE400-10000	10000	11950					1	2	2				
<b>AFDE410 Serie - 0.75 kW (1hp)</b>							<b>Ø mm</b>	<b>Ø mm</b>	<b>Ø mm</b>				
AFDE410-330	330	400	100	3.94	724	163	11	12	20				
AFDE410-550	550	660					10	12	20				
AFDE410-900	900	1100					9	11	19				
AFDE410-1200	1200	1450					8	10	18				
AFDE410-1450	1450	1740					7	10	16				
AFDE410-1750	1750	2100					6	9	14				
AFDE410-2350	2350	2820					5	8	12				
AFDE410-2850	2850	3400					4	6	11				
AFDE410-3750	3750	4500					2.5	6	10				
AFDE410-4600	4600	5450					2	5.5	7				
AFDE410-5250	5250	6300					2	5	6				
AFDE410-8000	8000	9600					1.5	4	4				
<b>AFDE610 Serie - 0.75 kW (1hp)</b>							<b>Ø mm</b>	<b>Ø mm</b>	<b>Ø mm</b>				
AFDE610-330	330	400					100	3.94	1557	350	12	20	22
AFDE610-550	550	660	10	18	20								
AFDE610-900	900	1100	10	16	20								
AFDE610-1200	1200	1450	7	14	16								
AFDE610-1450	1450	1740	6.5	12	14								
AFDE610-1750	1750	2100	6	12	14								
AFDE610-2350	2350	2820	4	10	11								
AFDE610-2850	2850	3400	3	6	8								
AFDE610-3750	3750	4500	2.5	5	6								
AFDE610-4600	4600	5450	2	4	5								
AFDE610-5250	5250	6300	1.5	3.5	4								
<b>AFDE620 Serie - 1.1 kW (1.47hp)</b>											<b>Ø mm</b>	<b>Ø mm</b>	<b>Ø mm</b>
AFDE620-330	330	400	100	3.94	1557	350					15	20	26
AFDE620-550	550	660									11	20	24
AFDE620-900	900	1100					10	18	20				
AFDE620-1200	1200	1450					8	16	18				
AFDE620-1450	1450	1740					6	14	17				
AFDE620-1750	1750	2100					5	12	16				
AFDE620-2350	2350	2820					4	10	13				
AFDE620-2850	2850	3400					3	6	9				
AFDE620-3750	3750	4500					2.5	5	7				
AFDE620-4600	4600	5450					2	4	6				
AFDE620-5250	5250	6300					1.5	3.5	5				

# How to select your AFD

## Pneumatic drive - Feed

TYPE AND SPEED	FREE SPEED NO LOAD	MAXIUM STROKE		DYNAMIC THRUST		MILD STEEL	ALUMINIUM	HARD WOOD
		rpm	mm	in.	N	lbf	Ø mm	Ø mm
<b>AFD205 Serie - 0.22 kW (0.30hp)</b>						Ø mm	Ø mm	Ø mm
AFD205-650	650	50	1.97	400	90	5	8	9.5
AFD205-1000	1000					4.5	7	9
AFD205-2700	2700					4	5	8
AFD205-4350	4350					2	4	6
AFD205-10000	10000					1	2	3
AFD205-18700	18700					0.5	1.2	1.5
<b>AFD215 Serie - 0.22 kW (0.30hp)</b>						Ø mm	Ø mm	Ø mm
AFD215-650	650	90	3.54	400	90	5	8	9.5
AFD215-1000	1000					4.5	7	9
AFD215-2700	2700					4	5	8
AFD215-4350	4350					2	4	6
AFD215-10000	10000					1	2	3
AFD215-18700	18700					0.5	1.2	1.5
<b>AFD415 Serie - 0.38 kW (0.51hp)</b>						Ø mm	Ø mm	Ø mm
AFD415-490	490	100	3.94	706	159	10	12	16
AFD415-790	790					10	11	16
AFD415-1250	1250					7	10.5	14
AFD415-2100	2100					6	10	12
AFD415-3400	3400					3	6	10
AFD415-5400	5400					2	4	6
AFD415-7000	7000					1.5	2.5	3.5
AFD415-18000	18000					1	1.5	2
<b>AFD684 Serie - 0.61 kW (0.82hp)</b>						Ø mm	Ø mm	Ø mm
AFD684-60	60	100	4	1735	390	14	20	22
AFD684-100	100					13	20	22
AFD684-160	160					13	20	22
AFD684-350	350					12	19	20
AFD684-550	550					11	16	16
AFD684-965	965					8	12	14
AFD684-2100	2100					4	8	12
AFD684-3300	3300					3	6	10

## General Data

### Multi Spindle Drilling

To calculate the cross sectional area of a drill diameter use the formula  $u(r^2)$  ( $3.14 \times \text{radius}^2$ )  
For example, Area of Ø 6mm hole  $3.14 \times 3 \times 3 = 28.26\text{mm}^2$

1. Calculate cross sectional area of hole by referring to the table below the formula.
2. Calculate the cross sectional area of a hole by the number of spindles.
3. Select the nearest greater hole cross sectional area from the table.
4. From the specification charts on pages 6 and 7 select the AFD with the appropriate capacity.

### Example - AFD415

5 off Ø 1.5mm holes to be drilled in aluminium -  $1.766 \times 5 = 8.83\text{mm}^2$   
Ø 4mm hole has a cross sectional area of  $12.56\text{mm}^2$

Therefore AFD415-5400 has adequate capacity to drill 5 off Ø 1.5mm holes in aluminium.

The above data is a guide for reference purposes only. Please read carefully the safety operating and maintenance instructions supplied with the unit prior to installing your Desoutter Auto Feed Drill. The performance data for air drive and feed functions are obtained with an air inlet pressure of 6,3 bar, and the speeds indicated are nominal. The capacities listed in this catalogue are for guidance only, and actual test and / or consultation with your local Desoutter Sales Representative is always recommended. Specifications are subject to change without prior notice.

Ø		AREA	
mm	lbf.in	mm <sup>2</sup>	lbf.in
1.0	1/32	0.785	0.0007
1.5	1/16	1.766	0.0003
2.0	3/32	3.14	0.006
2.5	1/8	4.91	0.012
3.0	5/32	7.06	0.019
4.0	3/16	12.56	0.027
5.0	7/32	19.62	0.037
6.0	1/4	28.26	0.049
7.0	9/32	38.47	0.062
8.0	5/16	50.24	0.076
9.0	11/32	63.59	0.092
10.0	3/8	78.50	0.110
11.0	13/32	94.99	0.129
12.0	7/16	113.04	0.150
13.0	15/32	132.67	0.172
14.0	1/2	153.86	0.196
15.0	9/16	176.63	0.248
16.0	5/8	200.96	0.306

# Electric drive - Pneumatic feed

## ■ AFDE200 - AFDE230

0.25 kW (0.34hp) - 850 to 11950 rpm

**COMPACT UNIT SIZE**

- High speed options up to 22400 rpm @ 50Hz, 26900 rpm @ 60Hz with K42 output
- Capacity upto 5mm (3/16») in aluminium
- Modular output spindles



For use with H21 Tapping Gearbox or Multi-spindle heads output spindle K35 is needed

Tapping gearbox & Accessories: see pages 22-32

MODEL	PART NUMBER	MODEL	PART NO.	SPEED		POWER		CURRENT		THRUST		STROKE		TAPPING TORQUE AVAILABLE	
				Canada CSA	575V (60Hz)	50HZ	60HZ	Motor power	50Hz	60Hz	Dynamic thrust	Working stroke	Nm	lbf.in	
				rpm	rpm	kW	hp	Amps	Amps	N	lbf	mm	in.	Nm	lbf.in
AFDE200-850	205 148 029 4	AFDE230-1000	205 148 030 4	850	1020	0.25	0.34	0.75	0.75	320	72	90	3.5	2.4	21.2
AFDE200-1200	205 148 022 4	AFDE230-1450	205 148 032 4	1200	1450	0.25	0.34	0.75	0.75	320	72	90	3.5	1.8	15.9
AFDE200-2350	205 148 023 4	AFDE230-2800	205 148 033 4	2350	2820	0.25	0.34	0.75	0.75	320	72	90	3.5	-	-
AFDE200-2850	205 148 024 4	AFDE230-3400	205 148 034 4	2850	3400	0.25	0.34	0.75	0.75	320	72	90	3.5	-	-
AFDE200-3750	205 148 025 4	AFDE230-4500	205 148 035 4	3750	4500	0.25	0.34	0.75	0.75	320	72	90	3.5	-	-
AFDE200-4600	205 148 026 4	AFDE230-5500	205 148 036 4	4600	5450	0.25	0.34	0.75	0.75	320	72	90	3.5	-	-
AFDE200-5250	205 148 027 4	AFDE230-6300	205 148 037 4	5250	6300	0.25	0.34	0.75	0.75	320	72	90	3.5	-	-
AFDE200-8000	205 148 028 4	AFDE230-9600	205 148 038 4	8000	9600	0.25	0.34	0.75	0.75	320	72	90	3.5	-	-
AFDE200-10000	205 148 021 4	AFDE230-12000	205 148 031 4	10000	11950	0.25	0.34	0.75	0.75	320	72	90	3.5	-	-

All models: Weight: 10.1 kg (22.2lb) - Air consumption per cycle: <0.032 l/s (<0.02 cfm) - Sound level: <70 dB(A)



# Electric drive - Pneumatic feed

AFDE200 - AFDE230 ■

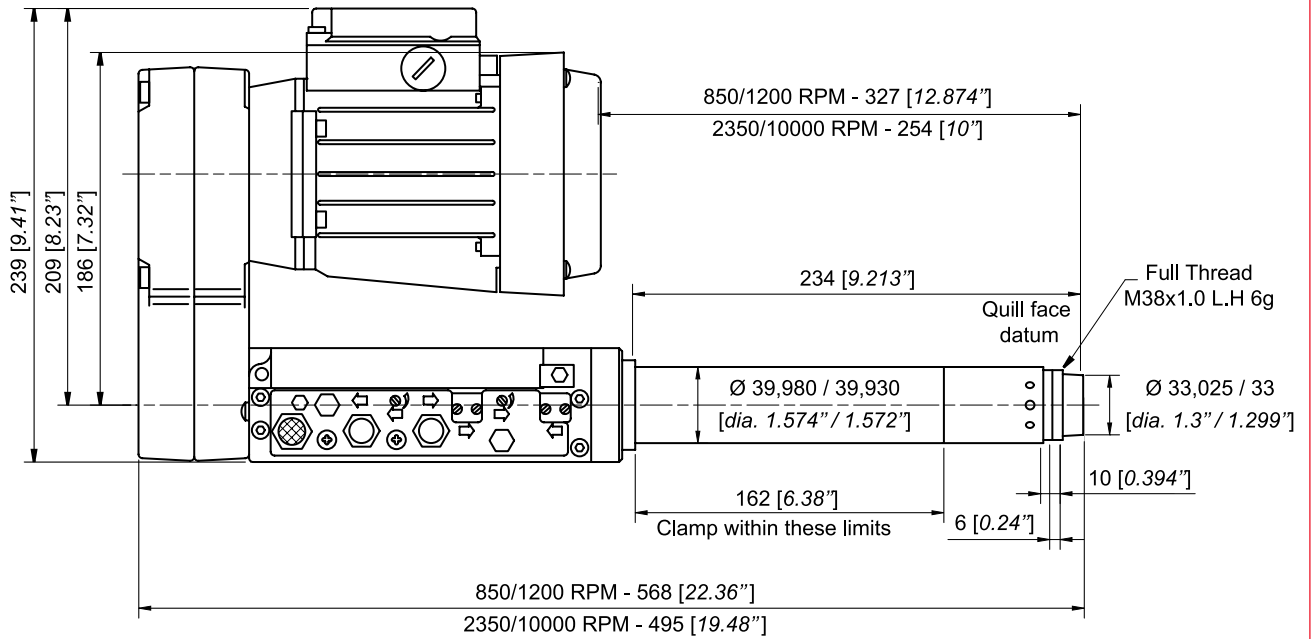
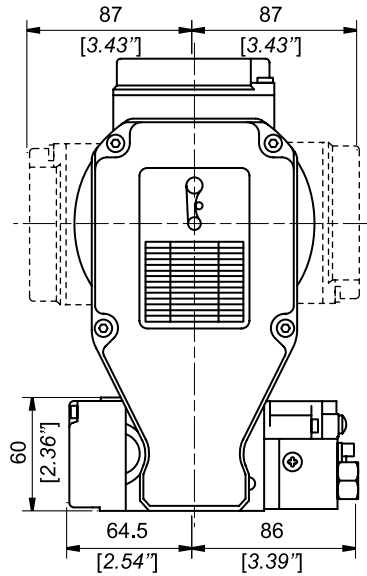

# Pneumatic drive - feed

## ■ AFD205 - AFD215

0.22 kW (0.30hp) - 650 to 18700 rpm

- Options of compact AFD205 or long stroke AFD215
- High thrust/size ratio
- Capacity up to 5mm (3/16») in aluminium
- Modular output spindles

**COMPACT UNIT SIZE**

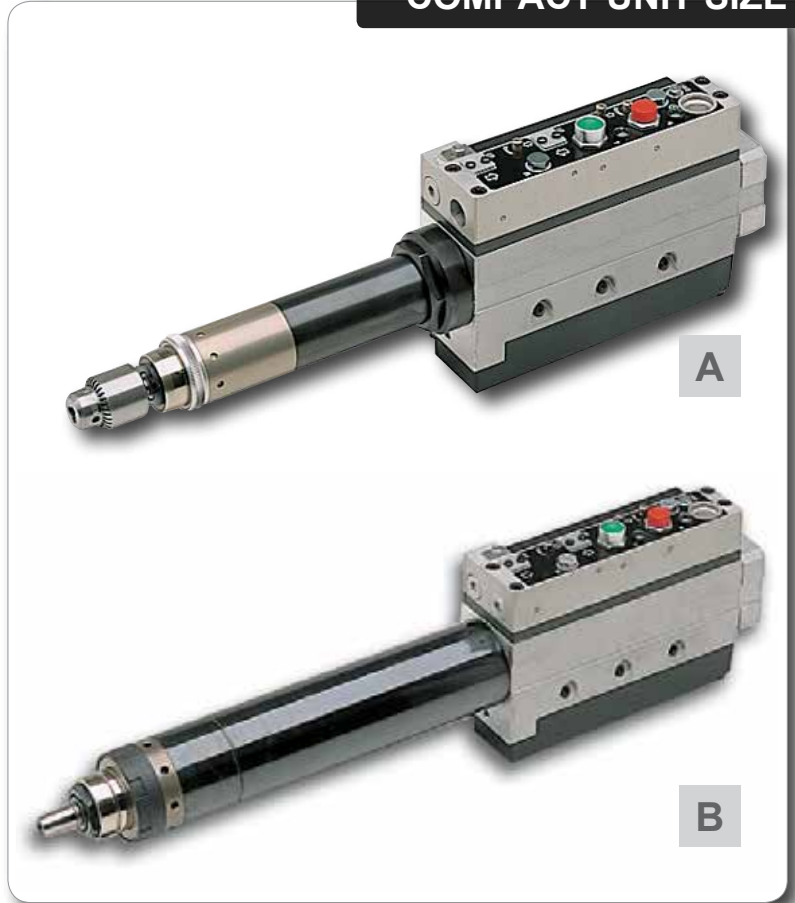

For use with H21 Tapping Gearbox or Multi-spindle heads output spindle K35 is needed

Tapping gearbox & Accessories: see pages 22-32

PIC. REF	MODEL	PART NUMBER	SPEED NO LOAD	POWER		THRUST		STROKE		WEIGHT		TAPPING TORQUE AVAILABLE	
				rpm	kW	hp	N	lbf	mm	in.	kg	lb	Nm
A	AFD205-650	205 148 005 4	650	0.22	0.30	400	90	50	1.97	3.9	8.6	4.3	38.1
A	AFD205-1000	205 148 001 4	1000	0.22	0.30	400	90	50	1.97	3.9	8.6	2.8	24.8
A	AFD205-2700	205 148 003 4	2700	0.22	0.30	400	90	50	1.97	3.9	8.6	-	-
A	AFD205-4350	205 148 004 4	4350	0.22	0.30	400	90	50	1.97	3.9	8.6	-	-
A	AFD205-10000	205 148 000 4	10000	0.22	0.30	400	90	50	1.97	3.9	8.6	-	-
A	AFD205-18700	205 148 002 4	18700	0.20	0.30	400	90	50	1.97	3.9	8.6	-	-
B	AFD215-650	205 148 011 4	650	0.22	0.30	400	90	90	3.54	4.2	9.2	4.3	38.1
B	AFD215-1000	205 148 007 4	1000	0.22	0.30	400	90	90	3.54	4.2	9.2	2.8	24.8
B	AFD215-2700	205 148 009 4	2700	0.22	0.30	400	90	90	3.54	4.2	9.2	-	-
B	AFD215-4350	205 148 010 4	4350	0.22	0.30	400	90	90	3.54	4.2	9.2	-	-
B	AFD215-10000	205 148 006 4	10000	0.22	0.30	400	90	90	3.54	4.2	9.2	-	-
B	AFD215-18700	205 148 008 4	18700	0.20	0.30	400	90	90	3.54	4.2	9.2	-	-

All models: Air consumption per cycle: 9.5 l/s (20 cfm) - Sound level: <75 dB(A)

# Pneumatic drive - feed

AFD205 - AFD215 ■

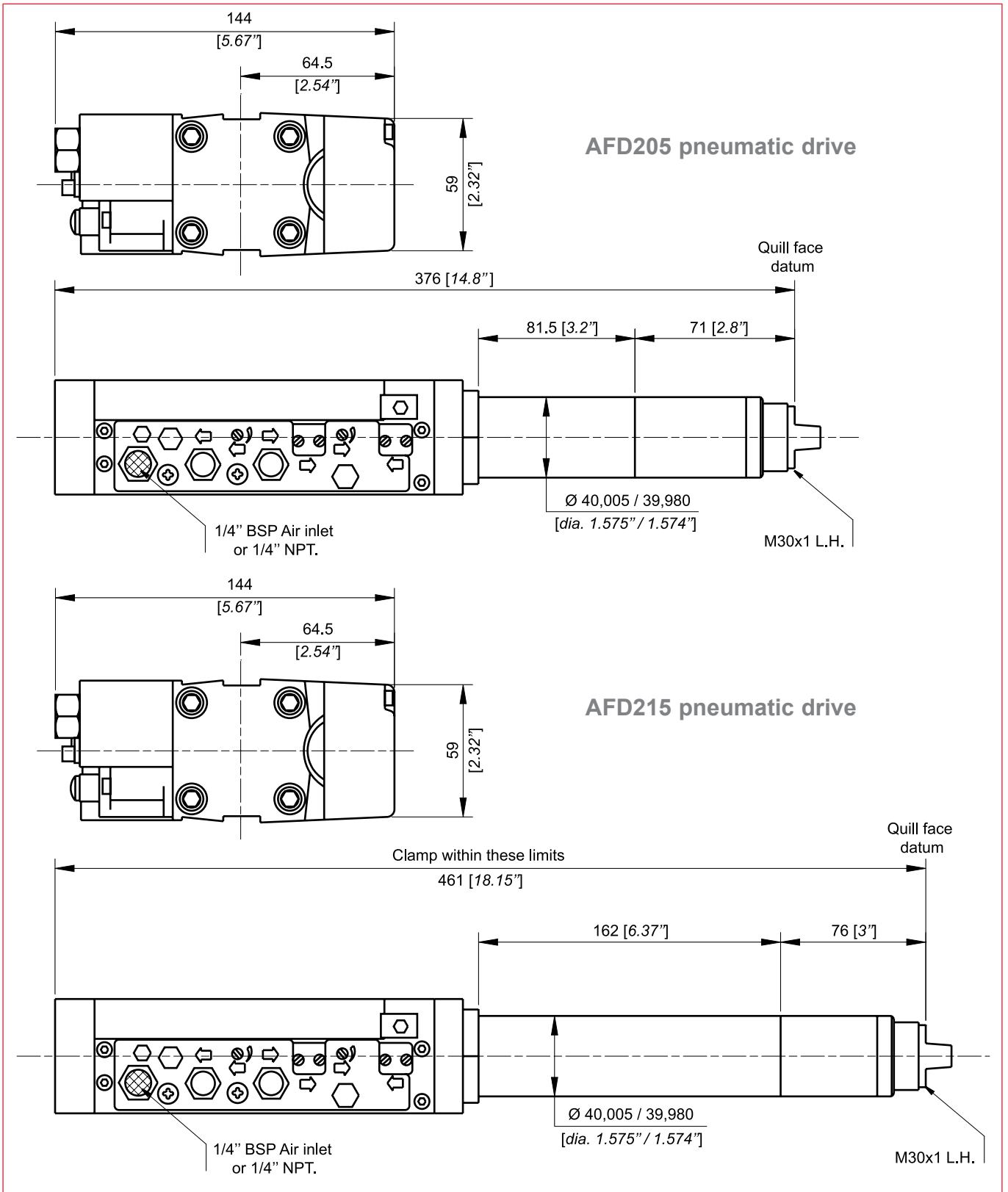

# Electric drive - Pneumatic feed

## ■ AFDE400 - AFDE430 - AFDE410 - AFDE440

0.33 - 0.75 kW (0.44 - 1hp) - 330 to 11950 rpm

- 330-10000 rpm @ 50Hz, 400-11900 rpm @ 60Hz
- 0.33kW (0.44HP) and 0.75kW (1.00HP) options
- Capacity up to 10mm (3/8») in aluminium, 8mm (5/16») in mild steel
- Spindle sealed to IP64 standard
- Modular output spindles

**VERSATILE RANGE**



For use with Multi-spindle heads output spindle B24 is needed

Tapping gearbox & Accessories: see pages 22-32

MODEL	PART NUMBER	MODEL	PART NO.	SPEED		POWER		CURRENT		THRUST		WEIGHT		TAPPING TORQUE AVAILABLE	
				CANADA CSA 575V (60HZ)		50Hz	60Hz	Motor power	50Hz	60Hz	Dynamic thrust		kg	lb	Nm
				rpm	rpm	kW	hp	Amps	Amps	N	lbf				
AFDE400-330	205 148 045 4	AFDE430-400	205 148 071 4	330	400	0.37	0.49	0.95	0.95	724	163	14.4	31.7	8.6	76.1
AFDE400-550	205 148 049 4	AFDE430-660	205 148 075 4	550	660	0.37	0.49	0.95	0.95	724	163	14.4	31.7	5.2	46.0
AFDE400-900	205 148 051 4	AFDE430-1100	205 148 064 4	900	1100	0.37	0.49	0.95	0.95	724	163	13.4	29.5	3.2	28.3
AFDE400-1200	205 148 040 4	AFDE430-1450	205 148 066 4	1200	1450	0.37	0.49	0.95	0.95	724	163	13.4	29.5	2.4	21.2
AFDE400-1450	205 148 041 4	AFDE430-1750	205 148 067 4	1450	1740	0.37	0.49	0.95	0.95	724	163	13.4	29.5	-	-
AFDE400-1750	205 148 042 4	AFDE430-2100	205 148 068 4	1750	2100	0.37	0.49	0.95	0.95	724	163	11.4	25.1	-	-
AFDE400-2350	205 148 043 4	AFDE430-2800	205 148 069 4	2350	2820	0.33	0.44	0.95	0.95	724	163	11.4	25.1	-	-
AFDE400-2850	205 148 044 4	AFDE430-3400	205 148 070 4	2850	3400	0.33	0.44	0.95	0.95	724	163	11.4	25.1	-	-
AFDE400-3750	205 148 046 4	AFDE430-4500	205 148 072 4	3750	4500	0.33	0.44	0.95	0.95	724	163	11.4	25.1	-	-
AFDE400-4600	205 148 047 4	AFDE430-5500	205 148 073 4	4600	5450	0.33	0.44	0.95	0.95	724	163	11.4	25.1	-	-
AFDE400-5250	205 148 048 4	AFDE430-6300	205 148 074 4	5250	6300	0.33	0.44	0.95	0.95	724	163	11.4	25.1	-	-
AFDE400-8000	205 148 050 4	AFDE430-9600	205 148 076 4	8000	9600	0.33	0.44	0.95	0.95	724	163	11.4	25.1	-	-
AFDE400-10000	205 148 039 4	AFDE430-12000	205 148 065 4	10000	12000	0.33	0.44	0.95	0.95	724	163	11.4	25.1	-	-
AFDE410-330	205 148 057 4	AFDE440-400	205 148 083 4	330	400	0.75	1.00	1.9	1.9	724	163	16.0	35.3	19.6	173.5
AFDE410-550	205 148 061 4	AFDE440-660	205 148 087 4	550	660	0.75	1.00	1.9	1.9	724	163	16.0	35.3	11.8	104.4
AFDE410-900	205 148 063 4	AFDE440-1100	205 148 077 4	900	1100	0.75	1.00	1.9	1.9	724	163	15.0	33.1	7.2	63.7
AFDE410-1200	205 148 052 4	AFDE440-1450	205 148 078 4	1200	1450	0.75	1.00	1.9	1.9	724	163	15.0	33.1	5.4	47.8
AFDE410-1450	205 148 053 4	AFDE440-1750	205 148 079 4	1450	1740	0.75	1.00	1.9	1.9	724	163	15.0	33.1	-	-
AFDE410-1750	205 148 054 4	AFDE440-2100	205 148 080 4	1750	2100	0.75	1.00	2.0	2.0	724	163	12.4	27.3	-	-
AFDE410-2350	205 148 055 4	AFDE440-2800	205 148 081 4	2350	2820	0.75	1.00	2.0	2.0	724	163	12.4	27.3	-	-
AFDE410-2850	205 148 056 4	AFDE440-3400	205 148 082 4	2850	3400	0.75	1.00	2.0	2.0	724	163	12.4	27.3	-	-
AFDE410-3750	205 148 058 4	AFDE440-4500	205 148 084 4	3750	4500	0.75	1.00	2.0	2.0	724	163	12.4	27.3	-	-
AFDE410-4600	205 148 059 4	AFDE440-5500	205 148 085 4	4600	5450	0.75	1.00	2.0	2.0	724	163	12.4	27.3	-	-
AFDE410-5250	205 148 060 4	AFDE440-6300	205 148 086 4	5250	6300	0.75	1.00	2.0	2.0	724	163	12.4	27.3	-	-
AFDE410-8000	205 148 062 4	AFDE440-9600	205 148 088 4	8000	9600	0.75	1.00	2.0	2.0	724	163	12.4	27.3	-	-

All models: Working stroke: 100mm (3.94") - Air consumption per cycle: <1 l/s (<0.04 cfm) - Sound level: <70 dB(A)

# Electric drive - Pneumatic feed

## AFDE400 - AFDE430 - AFDE410 - AFDE440

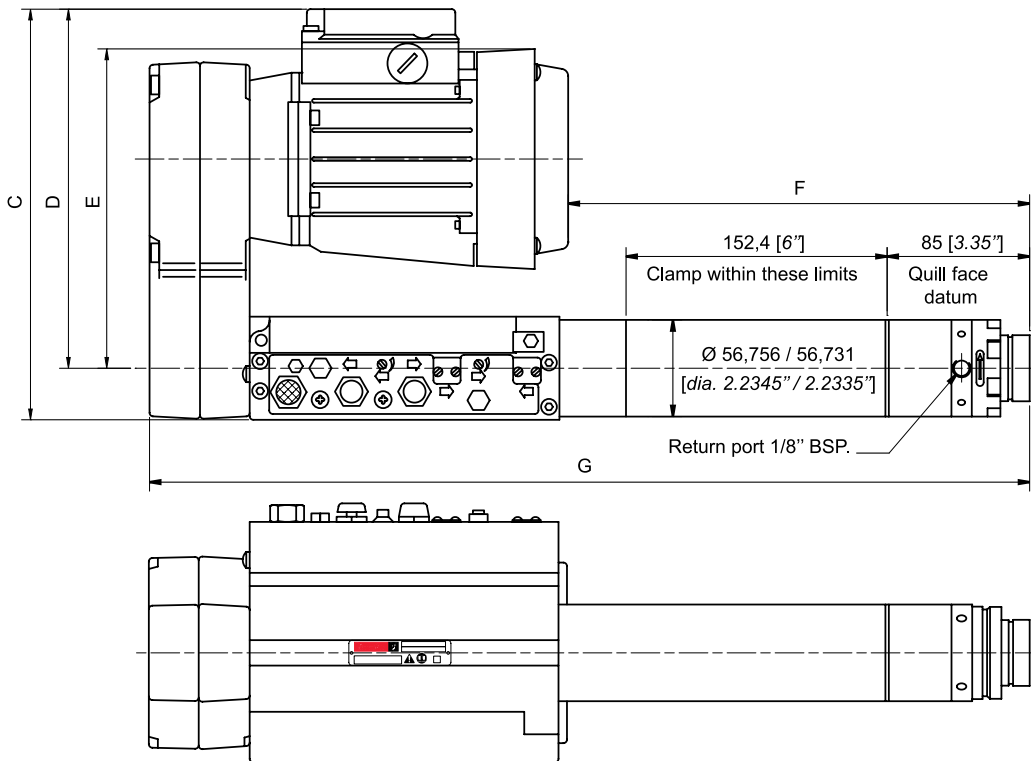
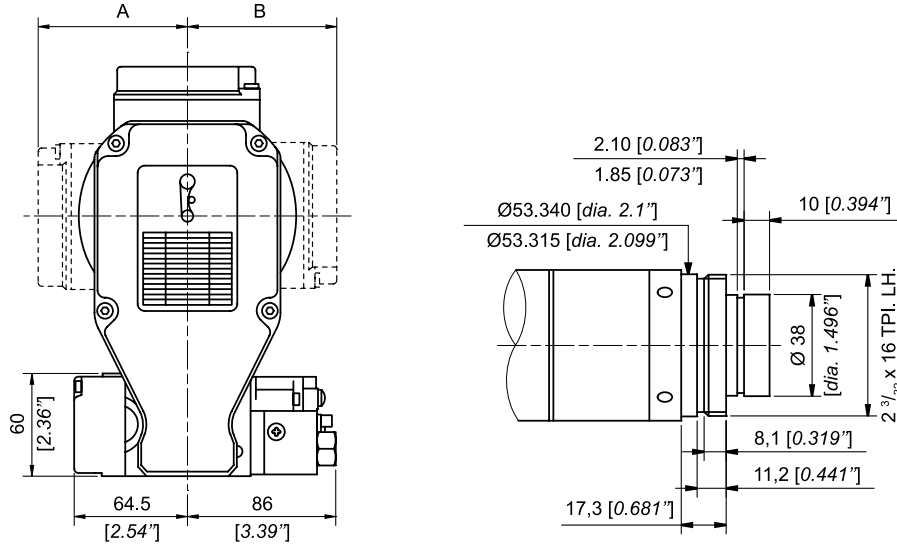

MODEL	A		B		C		D		E		F		G	
	mm	in.	mm	in.	mm	in.	mm	in.	mm	in.	mm	in.	mm	in.
AFDE400-330/-500	102	4.0	102	4.0	254	10.0	224	8.8	192	7.6	318	12.5	585	23.0
AFDE400-900/-1200/-1450	102	4.0	102	4.0	254	10.0	224	8.8	192	7.6	245	9.6	512	20.2
AFDE400-1750 to 10000	87	3.4	87	3.4	239	9.4	209	8.2	186	7.3	271	10.7	512	20.2
AFDE410-330/-550	112	4.4	112	4.4	264	10.4	234	9.2	201	7.9	295	11.6	585	23.0
AFDE410-900/-1200/-1450	112	4.4	112	4.4	264	10.4	234	9.2	201	7.9	222	8.7	512	20.2
AFDE410-1750 to 8000	102	4.0	102	4.0	254	10.0	224	8.8	192	7.6	245	9.6	512	20.2

# Pneumatic drive - feed

## ■ AFD415

0.38 kW (0.51hp) - 490 to 18000 rpm

- Long working stroke of 100mm (3.94»)»
- Spindle sealed to IP64 standard
- Capacity up to 10mm (3/8») in aluminium, 8mm (5/16») in mild steel
- Modular output spindles

### COMPACT UNIT AND VERSATILE RANGE

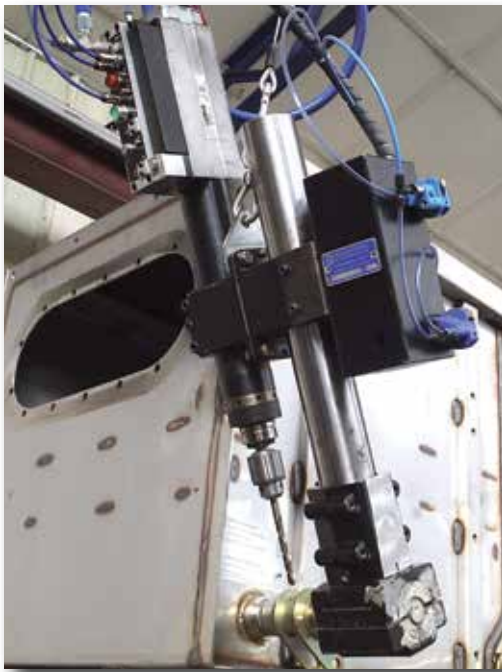

For use with Multi-spindle heads output spindle B24 is needed

Tapping gearbox & Accessories: see pages 22-32

MODEL	PART NUMBER	FREE SPEED NO LOAD	POWER		THRUST		STROKE		WEIGHT		TAPPING TORQUE AVAILABLE	
			Motor power	hp	Dynamic thrust	Working stroke	kg	lb	Nm	lbf.in		
		rpm	kW	hp	N	lbf	mm	in.	kg	lb	Nm	lbf.in
AFD415-490	205 148 016 4	490	0.38	0.51	706	159	100	3.94	6.2	13.7	9.9	87.6
AFD415-790	205 148 019 4	790	0.38	0.51	706	159	100	3.94	6.2	13.7	6.1	54.0
AFD415-1250	205 148 012 4	1250	0.38	0.51	706	159	100	3.94	6.2	13.7	3.9	34.5
AFD415-2100	205 148 014 4	2100	0.38	0.51	706	159	100	3.94	6.2	13.7	-	-
AFD415-3400	205 148 015 4	3400	0.38	0.51	706	159	100	3.94	6.2	13.7	-	-
AFD415-5400	205 148 017 4	5400	0.38	0.51	706	159	100	3.94	6.2	13.7	-	-
AFD415-7000	205 148 018 4	7000	0.38	0.51	706	159	100	3.94	6.2	13.7	-	-
AFD415-18000	205 148 013 4	18000	0.38	0.51	706	159	100	3.94	6.2	13.7	-	-

All models: Air consumption per cycle: 9.9 l/s (21 cfm) - Sound level: 75 dB(A)

# Pneumatic drive - feed

AFD415 ■

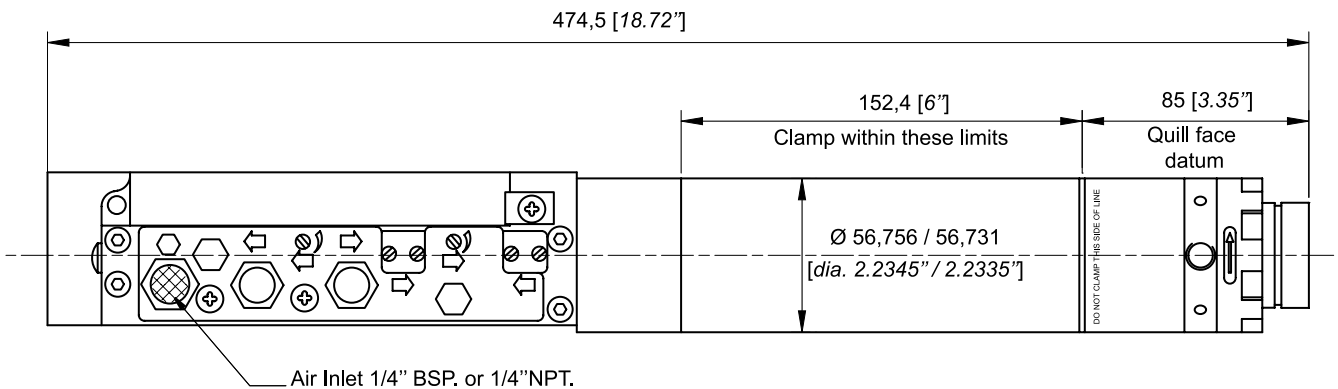
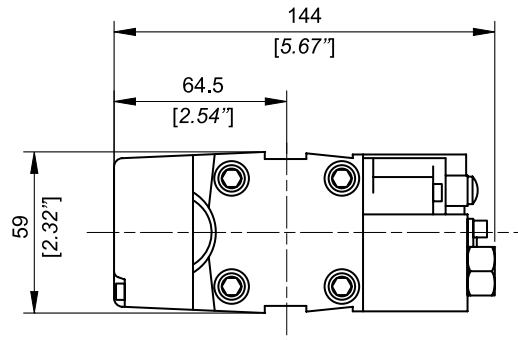
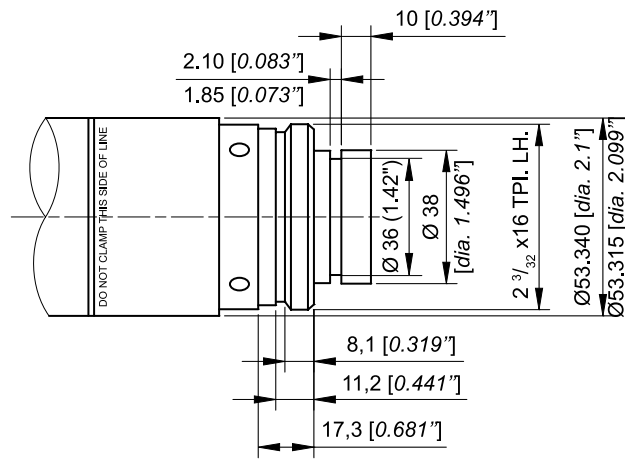

# Electric drive - Pneumatic feed

## ■ AFDE610 - AFD620 - AFDE640

0.75 to 1.1 kW (1 - 1.47hp) - 330 to 6300 rpm

- 2 power ratings to give optimum power/thrust combination
- Heavy duty belts and pulley drive with integral belt tensioner
- Capacity up to 12mm (1/2») in mild steel
- Spindle sealed to IP64 standard
- Modular output spindles

### HEAVY DUTY RANGE



For use with J19 Tapping Gearbox or Multi-spindle heads output spindle B24 is needed see pages 24-25

Tapping gearbox & Accessories: see pages 22-32

MODEL	PART NO.	MODEL CANADA CSA 575V (60HZ)	PART NO.	SPEED		POWER		CURRENT		THRUST		WEIGHT		TAPPING TORQUE AVAILABLE	
				50Hz	60Hz	Motor power	50Hz	60Hz	Dynamic thrust	kg	lb	Nm	lbf.in		
AFDE610-330	205 148 094 4	AFDE640-400	205 148 117 4	330	400	0.75	1.00	1.9	1.9	1557	350	21.0	46.3	19.6	173.5
AFDE610-550	205 148 098 4	AFDE640-660	205 148 121 4	550	660	0.75	1.00	1.9	1.9	1557	350	21.0	46.3	11.8	104.4
AFDE610-900	205 148 099 4	AFDE640-1100	205 148 111 4	900	1100	0.75	1.00	1.9	1.9	1557	350	20.0	44.1	7.2	63.7
AFDE610-1200	205 148 089 4	AFDE640-1450	205 148 112 4	1200	1450	0.75	1.00	1.9	1.9	1557	350	20.0	44.1	5.4	47.8
AFDE610-1450	205 148 090 4	AFDE640-1750	205 148 113 4	1450	1740	0.75	1.00	2.0	2.0	1557	350	20.0	44.1	-	-
AFDE610-1750	205 148 091 4	AFDE640-2100	205 148 114 4	1750	2100	0.75	1.00	2.0	2.0	1557	350	18.4	40.5	-	-
AFDE610-2350	205 148 092 4	AFDE640-2800	205 148 115 4	2350	2820	0.75	1.00	2.0	2.0	1557	350	18.4	40.5	-	-
AFDE610-2850	205 148 093 4	AFDE640-3400	205 148 116 4	2850	3400	0.75	1.00	2.0	2.0	1557	350	18.4	40.5	-	-
AFDE610-3750	205 148 095 4	AFDE640-4500	205 148 118 4	3750	4500	0.75	1.00	2.0	2.0	1557	350	18.4	40.5	-	-
AFDE610-4600	205 148 096 4	AFDE640-5500	205 148 119 4	4600	5450	0.75	1.00	2.0	2.0	1557	350	18.4	40.5	-	-
AFDE610-5250	205 148 097 4	AFDE640-6300	205 148 120 4	5250	6300	0.75	1.00	2.0	2.0	1557	350	18.4	40.5	-	-
AFDE620-330	205 148 105 4			330	400	1.1	1.47	2.8	2.8	1557	350	21	46.3	19.6	173.5
AFDE620-550	205 148 109 4			550	660	1.1	1.47	2.8	2.8	1557	350	21	46.3	11.8	104.4
AFDE620-900	205 148 110 4			900	1100	1.1	1.47	2.8	2.8	1557	350	20	44.1	7.2	63.7
AFDE620-1200	205 148 100 4			1200	1450	1.1	1.47	2.8	2.8	1557	350	20	44.1	5.4	47.8
AFDE620-1450	205 148 101 4			1450	1740	1.1	1.47	2.8	2.8	1557	350	22	48.4	-	-
AFDE620-1750	205 148 102 4			1750	2100	1.1	1.47	2.8	2.8	1557	350	22	48.4	-	-
AFDE620-2350	205 148 103 4			2350	2820	1.1	1.47	2.8	2.8	1557	350	22	48.4	-	-
AFDE620-2850	205 148 104 4			2850	3400	1.1	1.47	2.8	2.8	1557	350	22	48.4	-	-
AFDE620-3750	205 148 106 4			3750	4500	1.1	1.47	2.8	2.8	1557	350	22	48.4	-	-
AFDE620-4600	205 148 107 4			4600	5450	1.1	1.47	2.8	2.8	1557	350	22	48.4	-	-
AFDE620-5250	205 148 108 4			5250	6300	1.1	1.47	2.8	2.8	1557	350	22	48.4	-	-

All models: Working stroke: 100 mm (3.94")

Air consumption per cycle: <2.5 l/s (<0.09 cfm) - Sound level: <70 dB(A)



# Electric Drive - Pneumatic Feed

## AFDE610 - AFDE640

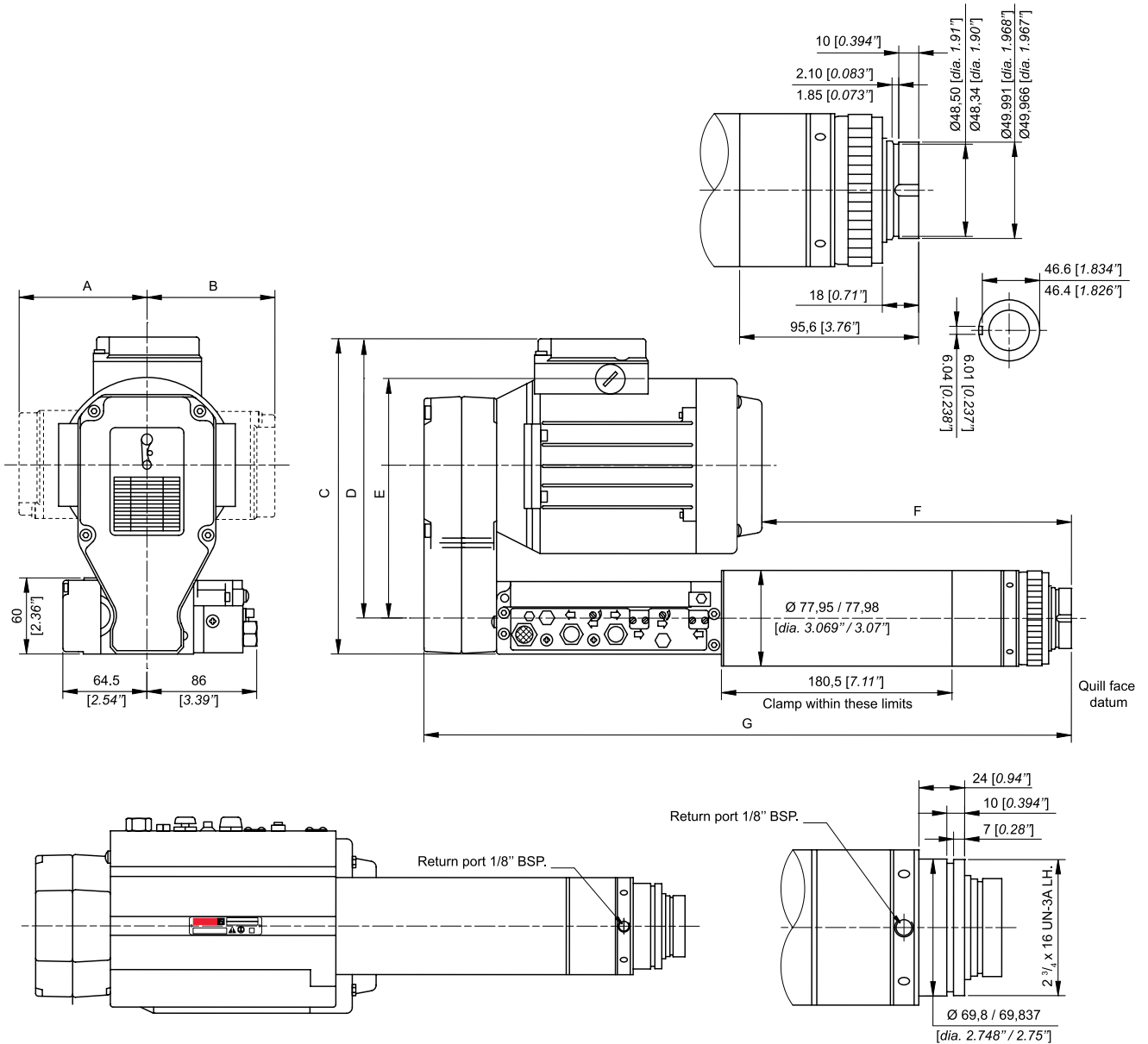

MODEL	A		B		C		D		E		F		G	
	mm	in.	mm	in.	mm	in.	mm	in.	mm	in.	mm	in.	mm	in.
AFDE610-330/550	112	4.4	112	4.4	264	10.4	234	9.2	201	7.9	297	11.7	588	23.1
AFDE610-900/1200/1450	112	4.4	112	4.4	264	10.4	234	9.2	201	7.9	224	8.8	515	20.3
AFDE610-1750-5250	102	4.0	102	4.0	254	10.0	224	8.8	192	7.6	247	9.7	515	20.3
AFDE620-330/550	112	4.4	112	4.4	264	10.4	234	9.2	201	7.9	297	11.7	588	23.1
AFDE620-900 to 5250	112	4.4	112	4.4	264	10.4	234	9.2	201	7.9	224	8.8	515	20.3

# Pneumatic drive - feed

## ■ AFD684

0.61 kW (0.82hp) - 60 to 3300 rpm

**HIGHER PNEUMATIC POWER**



For use with J19 Tapping Gearbox or Multi-spindle heads output spindle B24 is needed

### How to Order AFD684:

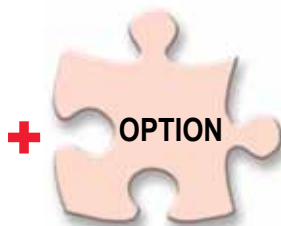
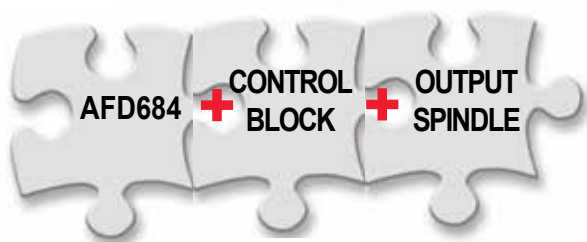

Tapping gearbox & Accessories: See pages 22-32

MODEL	PART NO.	SPEED	POWER		THRUST		STROKE		WEIGHT		TAPPING TORQUE AVAILABLE	
			Motor power		Dynamic thrust		Working stroke					
		rpm	kW	hp	N	lbf	mm	in.	kg	lb	Nm	lbf.in
AFD684-60	615 176 035 0	60	0.6	0.8	1735	390	100	4	16.5	36.4	41.0	363
AFD684-100	615 176 036 0	100	0.6	0.8	1735	390	100	4	16.5	36.4	41.0	363
AFD684-160	615 176 037 0	160	0.6	0.8	1735	390	100	4	16.5	36.4	41.0	363
AFD684-350	615 176 038 0	350	0.6	0.8	1735	390	100	4	16.5	36.4	31.0	274
AFD684-550	615 176 039 0	550	0.6	0.8	1735	390	100	4	16.5	36.4	21.0	186
AFD684-965	615 176 040 0	965	0.6	0.8	1735	390	100	4	16.5	36.4	13.0	115
AFD684-2100	615 176 041 0	2100	0.6	0.8	1735	390	100	4	16.5	36.4	5.6	50
AFD684-3300	615 176 042 0	3300	0.6	0.8	1735	390	100	4	16.5	36.4	3.8	34

Drilling performance specification  
Silencers for Air Motors are not supplied with complete tools

Air consumption per cycle: 16.5 l/s (35 cfm) - Sound level: <87 dB(A)

# Pneumatic drive - feed

**AFD684** ■

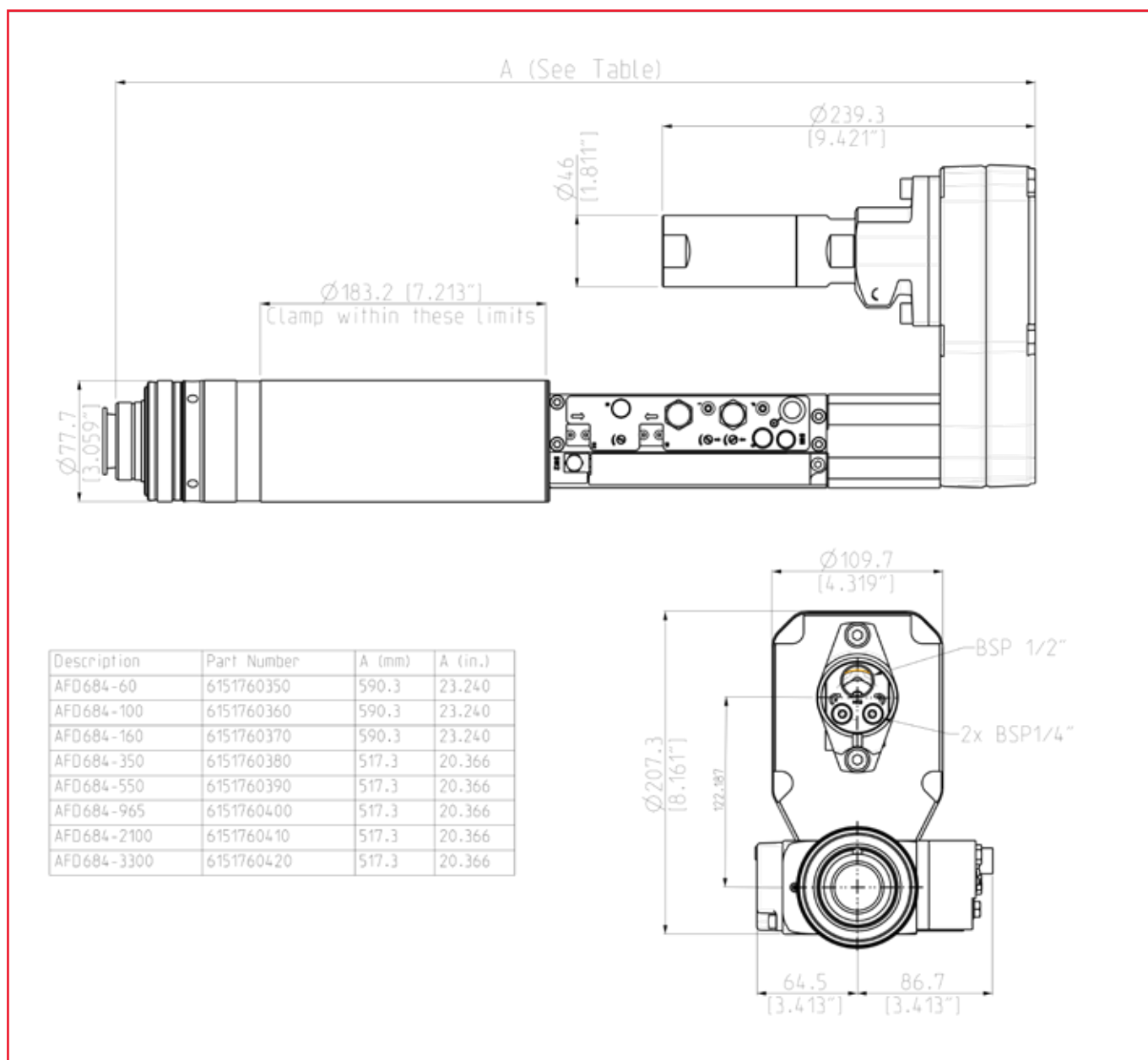

## SILENCER



## OPTIONAL ACCESSORIES

	PART NO.
1 Silencer - sinter bronze (noise clamp 15 dB(A) - Power loss 10)	205 054 1743
2 Silencer (noise clamp 20 dB(A) - Power loss 10)	205 054 1773
3 Silencer (noise clamp 25 dB(A) - Power loss 7)	205 054 1783

# Electric drive - Leadscrew feed

## ■ AFTE480

0.75 kW (1hp) - 180 to 1740 rpm

- High power brake motors with 0.75kW (1 HP)
- Supplied fitted with proximity switches for depth, datum and 'no hole' sensing, PNP
- Quick release interchangeable lead-screw and nut assembly
- Capacity up to 10mm (3/8») in mild steel, 16mm (5/8») in aluminium depending on thread form

### HIGH POWER AND ACCURACY



Optional NPN Switches kit available:  
(P.N. 205 055 928 3)

### Leadscrew/nut assemblies AFTE480

SHAPE	REPLACEMENT LEADSCREW / NUT ONLY	ORDERING CODE	THREAD SIZE / PITCH	REPLACEMENT LEADSCREW / NUT ONLY	ORDERING CODE	THREAD SIZE / PITCH
	PART NO.			PART NO.		
	350713	L01	0.50mm	350833	L13	28TPI
	350723	L02	0.60mm	350853	L15	24TPI
	350733	L03	0.70mm	350873	L17	20TPI
	350743	L04	0.75mm	350893	L19	18TPI
	350753	L05	0.80mm	350903	L20	16TPI
	350763	L06	1.00mm	350943	L25	2BA
	350773	L07	1.25mm	350993	L22	1/8"NPT
	350783	L08	1.50mm	359293	L30	0.45mm
	350793	L09	1.75mm	369933	L33	0.30mm
	350803	L10	40TPI	380373	L34	0.25mm
	350823	L12	32TPI			

Quick release Leadscrew and Nut Assembly

Other leadscrews available to special order.

Accessories: see pages 22-32

MODEL	PART NO.	SPEED		POWER		CURRENT		TORQUE		STROKE		WEIGHT	
		50Hz	60Hz	Motor power		50Hz	60Hz	Tapping torque available		Pitch controlled stroke		kg	lb
		rpm	rpm	kW	hp	Amps	Amps	Nm	lbf.in	mm	in.		
AFTE480-180	205 148 124 4	180	215	0.75	1.00	2.0	2.0	35.8	316.8	60	2.36	26.5	58.3
AFTE480-330	205 148 125 4	330	400	0.75	1.00	2.0	2.0	19.5	172.8	60	2.36	26.5	58.3
AFTE480-550	205 148 126 4	550	660	0.75	1.00	2.0	2.0	11.7	103.7	60	2.36	26.5	58.3
AFTE480-900	205 148 127 4	900	1080	0.75	1.00	2.0	2.0	7.2	63.4	60	2.36	26.5	58.3
AFTE480-1200	205 148 122 4	1200	1440	0.75	1.00	2.0	2.0	5.4	47.5	60	2.36	26.5	58.3
AFTE480-1450	205 148 123 4	1450	1740	0.75	1.00	2.0	2.0	4.4	39.3	60	2.36	26.5	58.3

Drilling performance specification

Sound level: <70 dB(A)

# Electric drive - Leadscrew feed

AFTE480 ■

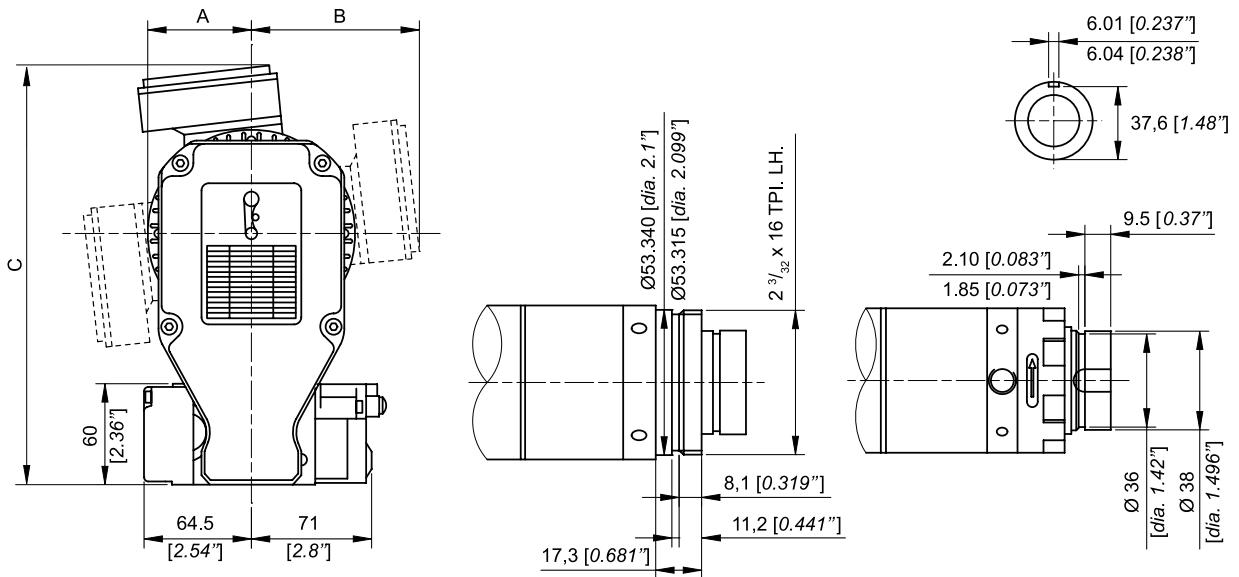
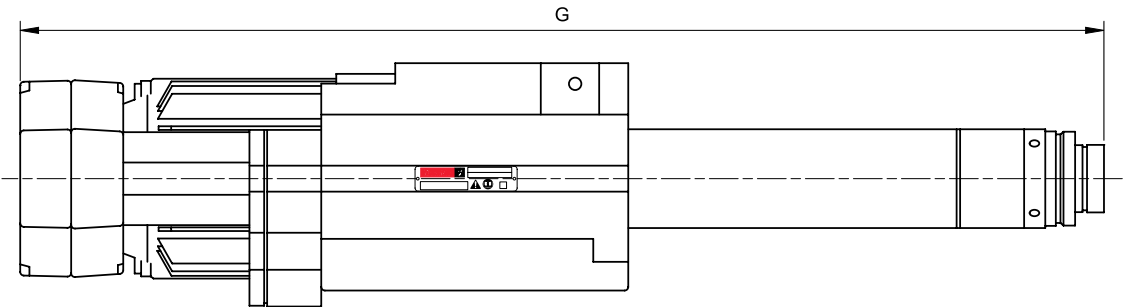
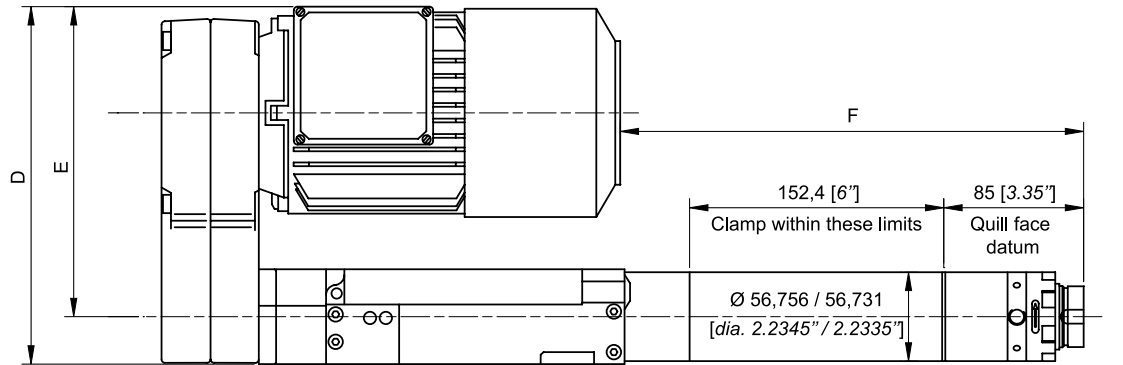

MODEL	A		B		C		D		E		F		G	
	mm	in.	mm	in.	mm	in.	mm	in.	mm	in.	mm	in.	mm	in.
AFTE480-180/330/550	70	2.8	116	4.6	268	10.6	222	8.7	192	7.6	280	11.0	625	24.6
AFTE480-900/1200/1450	70	2.8	116	4.6	268	10.6	222	8.7	192	7.6	207	8.2	552	21.7

# Control Blocks and Interfaces

## Control Blocks

**A1 Full Feature  
Control Block  
Part No. 436313**

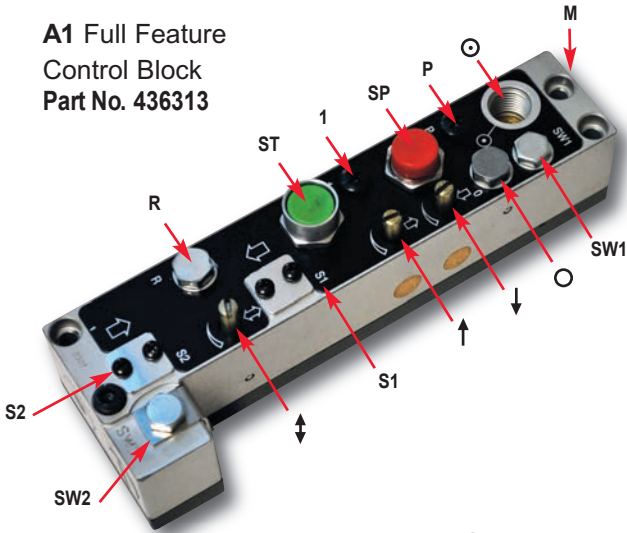

**A6 Simple  
Control Block  
Part No. 103862**

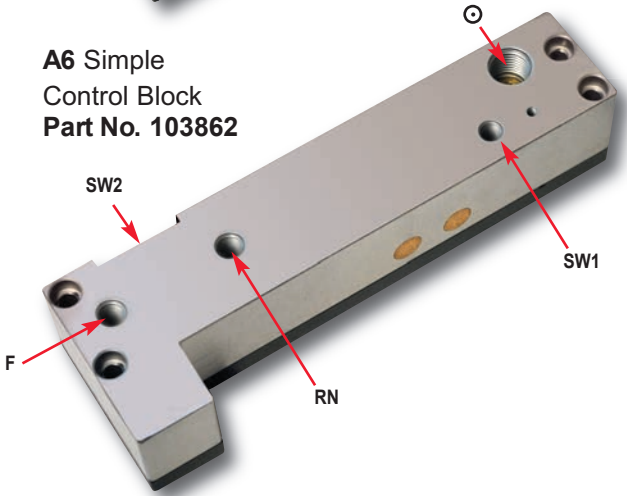

### Air Connections

- R** Air Return Port – Connects to breather port in the nose of the tool to provide extra retract capability with heavy front end attachments (10-32)
- ST** Start Button – For manual operation and set-up
- 1** Remote Start Signal Port Pulse (10-32)
- SP** Manual Stop Button – Interrupts cycle and returns AFD to datum
- P** Remote Stop Signal Port – Requires external signal pulse for returning the unit to datum rest position (10-32)
- ⊙ Air inlet (1/4" BSP or 1/4" NPT)
- M** Work Cycle Complete Port – Used for sequence control with other AFD's clamps, index tables, etc (positive at datum position) (10-32)
- Depth Stop Signal Port – Used with external circuits such as dwell or pecking (10-32)
- ↑ Retract rate adjustment control
- ↓ Advance rate adjustment control
- ↕ Feed rate adjustment control
- F** Feed port (1/8" NPT)
- RN** Return port (1/8" NPT)

### Electrical Connections

- S1** Start solenoid
- S2** Stop solenoid
- SW1** Datum return (M8 x 1.00)
- SW2** Depth position (M8 x 1.00)

## Electrical Interfaces (not included with control blocks)

### **C3 Part No. 104002**

Comprises:  
2 x M8 Proximity Switches PNP (NO)  
2 x Plug-in Cables

### **C5 Part No. 104842**

Comprises:  
2 x M8 Proximity Switches NPN (NO)  
2 x Plug-in Cables

### **Solenoid Valves**

All 24V DC  
NC – Valve normally closed  
NO – Valve normally open

### **Proximity Switches**

All 10-30V DC  
NC – Normally closed  
NO – Normally open

### **C10 Part No. 438223**

Comprises:  
2 x M8 Proximity Switches PNP  
2 x Plug-in Cables  
2 x Solenoid Valves (NC)

### **C11 Part No. 438233**

Comprises:  
2 x M8 Proximity Switches PNP  
2 x Plug-in Cables  
1 x Solenoid Valve (NC)  
1 x Solenoid Valve (NO)

### **C12 Part No. 438243**

Comprises:  
2 x M8 Proximity Switches NPN  
2 x Plug-in Cables  
2 x Solenoid Valves (NC)

## AFD Control Options ■

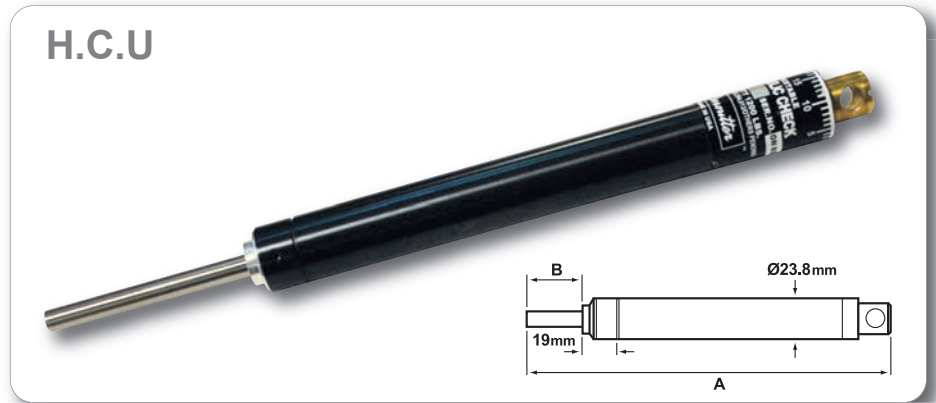

	MIN. PLUNGER OPERATING LOAD		MAX. LOAD		MINIMUM FEED RATE AT 2230N (500LBS) LOAD		MAX. STROKE		A		B		PART NO.
	kg	lbs	kg	lbs	mm/sec	in/sec	mm	in	mm	in	mm	in	
D1	2.3	5	544	1200	0.73	0.029	25	1	199	7.83	30.1	1.19	91942
D2	2.3	5	544	1200	0.73	0.029	50	2	276	10.87	55.5	2.19	91952
D3	2.3	5	544	1200	0.73	0.029	75	3	352	13.86	80.9	3.19	91962
D7	4.1	9	357	785	0.45	0.018	102	4	417	16.42	106	4.17	104452

Each of these H.C.U unit needs the conversion Kit Part Number 94982 to be installed

### Peck feed control

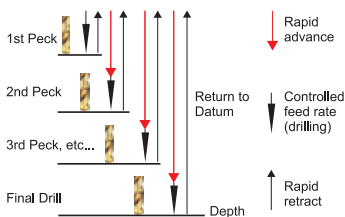

Used when hole depth is five times hole diameter. Helps clear chips, avoids overheating and bit breakage. Hole accuracy is improved. For use with Full Feature Control Block A1 (0-10 seconds)

	STROKE	PART NO.
D4	25mm (1")	92282
D5	50mm (2")	92292
D6	75mm (3")	92302

### Dwell control

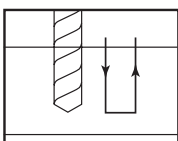

Used to dwell drill bit at the bottom of the stroke. Can be used to spot face, blind hole polish, friction weld plastic components and spin rivet. For use with Full Feature Control Block.

	DESCRIPTION	PART NO.
E1	Dwell Control Unit Complete	92372

### Skip feed control

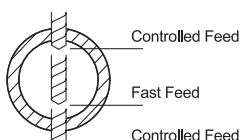

Skip drilling - custom H.C.U's available on request. Skip control ensures minimum cycle times without breakthrough burrs when drilling tubes, pocketed castings etc, with two controlled feeds, and fast travel through the empty space.

Information Required  
 1. Depth of first cut  
 2. Depth of skip  
 3. Depth of second cut  
 4. Drill point angle

# Accessories

## OUTPUT SPINDLES

- Interchangeable modular output spindles
- Precision option for collet types, R2 and R36



### AFDE200/230 - AFD205 - AFD215





	FUNCTION	ORDER CODE	FEATURES	PART NO.	RECOMMENDED SPEED RANGE
	High Speed Output Spindle	K42	Collet Chuck can be fitted to any AFDE200 to step up speed by 4.28 : 1. Note: Max. allowable speed 27000 rpm. See page 28 for collets.	375263	5250 rpm
	Collet Chuck	K2	See page 28 for range of collets.	357183	18800 rpm
	No. 1 Jacobs Taper Output Spindle	K32	No. 1 Jacobs Taper and for use with chucks A = 23mm (0.91")	449733	9600 rpm
		K35	No. 1 Jacobs Taper and for use with tapping or multi spindle heads - A = 15.5mm (0.61")	455773	
	Tapping Head Output Spindle	H21	4.5-8.0mm (3/16"-5/16") capacity Use with K35	357193	1200 rpm

### AFDE400/430 - AFDE410/440 - AFD415 - AFDE610/640 - AFDE620 - AFDE625 - AFTE480



	FUNCTION	ORDER CODE	FEATURES	PART NO.	RECOMMENDED SPEED RANGE												
	10mm (3/8") Key Adjustable Chuck Output Spindle	B1	Part No. includes chuck key	327723	9600												
	Integral Collet Chuck Output Spindle	B2	Up to 7mm (0.276") collet capacity (see page 28 for Collet Range)	326573	18000												
		R2	Standard Output Assembly Precision Output Assembly	384113													
	Large Integral Collet Chuck Output Spindle	R36	Up to 16mm (0.63") collet capacity (see page 28 for Collets)	389273	18000												
			Precision Output Assembly														
	Taper Output Spindle and for use with chucks and multi spindle heads	B24	No. 2 Jacobs Taper A = 30 (1.18")	326593	9600												
		B32	No. 1 Jacobs Taper A = 24.1 (0.95")	355263													
		B16	B16 Taper Output A = 34.8 (1.37")	368163													
	Preset Tooling DIN55058 Output Spindle		<table border="1"> <thead> <tr> <th>ØA</th> <th>ØB</th> <th>C</th> <th>D</th> </tr> <tr> <th>mm</th> <th>mm</th> <th>mm</th> <th>mm</th> </tr> </thead> <tbody> <tr> <td>16</td> <td>25</td> <td>74</td> <td>79</td> </tr> </tbody> </table>	ØA	ØB	C	D	mm	mm	mm	mm	16	25	74	79		5450
		ØA	ØB	C	D												
mm	mm	mm	mm														
16	25	74	79														
B3	Standard Output Assembly	326563															
	AFD415, AFDE400 Externally Adjustable Screwdriver Head Output Spindle	B5	1/4" fem. hex. drive. Torque range 0.3 - 11 Nm (2.7 - 100 ins. lbs.)	324903	2100												
		B6	5/16" fem. hex. drive. Torque range 0.3 - 11 Nm (2.7 - 100 ins. lbs.)	324913													
	AFD415, AFDE400/410 Tapping Head Output Spindle	B7	4.5-8mm (3/16"-5/16") capacity	92362	1450												
		B8	3.5-6.5mm (9/64"-1/4") capacity	92892													
	AFDE600/610 Tapping Head Output Spindle	J19	4.5 - 9.5mm (3/16" - 3/8") capacity For use with B24 output	383813	1450												

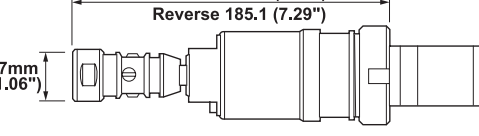

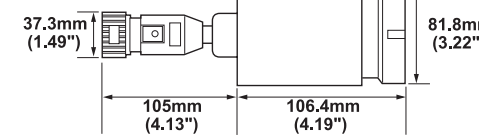

## "PUSH PULL" TAPPING HEADS

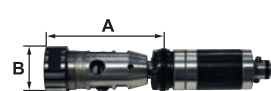
<b>AFDE200 Serie</b> 		<b>H21 Tapping Gearbox</b> <b>Part No. 357193</b> Capacity 4.5-8mm (3/16"-5/16") Use with K35 output
<b>AFDE400 Serie</b> 		<b>B7 Tapping Gearbox</b> <b>Part No. 92362</b> Capacity 3.5-6.5mm (9/64"-1/4") <b>B8 Tapping Gearbox</b> <b>Part No. 92892</b> Capacity 4.5-8mm (3/16"-5/16")
<b>AFDE610 Serie</b> 		<b>J19 Tapping Gearbox</b> <b>Part No. 383813</b> Capacity 4.5-9.5mm (3/16"-3/8") Use with B24 output

## TAPPING CHUCKS

	FUNCTION	JACOBS TAPER FITTING	A		B		Ø TAP SHANK		CHUCK PART NO.	
			mm	in.	mm	in.	mm	in.		
Optional Collets 	Tapping Chucks with flexible Collet (included)	No. 1	64	2.5	27	1.1	3.5-6.5	9/64-1/4	29462	
		No. 1	64	2.5	27	1.1	4.5-8	3/16-5/16	29452	
		No. 2	79	3.1	37	1.5	4.5-9.5	3/16-3/8	34742	
	Spare or replacement Collets	2-4.5mm (5/65-3/16") Capacity to suit 29462/29452							75142	
		3.5-6.5mm (9/64-1/4") Capacity to suit 29462/29452							29482	
		4.5-8mm (3/16-5/16") Capacity to suit 29462/29452								29472
		4.5-9.5mm (3/16-3/8") Capacity to suit 34742								36172
		9-12.5mm (9/32-1/2") Capacity to suit 34742								39242

## DRILLING CHUCKS

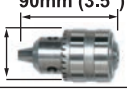
	FUNCTION	DESCRIPTION	PART NO.
Max Drill 6.5mm (1/4") Depth 15mm (0.59") 	6.5mm (1/4") Key Adjustable Chuck	Part No. includes Chuck Key. Use with No. 1 standard Jacobs taper outputs K32 and B32	29492
Max Drill 10mm (3/8") Depth 34mm (1.34") 	10mm (3/8") Key Adjustable Chuck	Part No. includes Chuck Key. Use with No. 2 standard Jacobs taper outputs B24	34752
Max Drill 10mm (3/8") Depth 52mm (2.04") 	10mm (3/8") Key Adjustable Chuck	Part No. includes Chuck Key. Use with No. 1 standard Jacobs taper outputs B24	29042
Max Drill 13mm (1/2") Depth 52mm (2.04") 	13mm (1/2") Key Adjustable Chuck	Part No. includes Chuck Key. Use with No. 1 standard Jacobs taper outputs B24	34332

## MORSE ADAPTOR

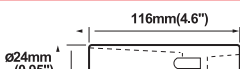
	FUNCTION	DESCRIPTION	PART NO.
	Morse Taper Adaptor	No.2 Jacobs female taper to No.2 Morse female taper	34862

No.2 Morse Taper    No.2 Jacobs Taper

# Multiple Spindle Heads



- Range of adjustable spindle positions for 2 and 3 spindle heads
- Special fixed spindle heads available for non standard hole patterns or dedicated applications

TYPE OF HEAD	NUMBER OF SPINDLES	SPINDLE CENTRE OR PC		MAXIMUM COLLET SIZE		AFD205 AFD215 AFDE200/230	AFD415 AFDE400/430 AFDE410/440	AFDE610/640 AFD684	AFTE480	COLLET TYPE (SEE PAGE 28)
		mm	in.	mm	in.	PART NO.	PART NO.	PART NO.	PART NO.	
<b>DRILLING</b>										
A	2	9.5-54	0.37-2.13	4.0	0.157	174183	92142			A
A	2	12.7-64	0.50-2.52	6.5	0.256		92152			B
A	2	19.0-95	0.75-3.74	9.5	0.374		106662	106672		D
A	2	41.1-109.9	1.62-4.33	7.0	0.276		92172			D
B	3 inline	19.0-57.1	0.75-2.25	9.5	0.374		107552	107562		D
C	3PCD	27.9-104.1	1.01-4.01	9.5	0.374			107592		D

## TAPPING

A	2	9.5-54	0.37-2.13	4.0	0.157				92142	A
A	2	12.7-64	0.50-2.52	6.5	0.256	204173	92222		92152	B
A	2	19.0-95	0.75-3.74	9.5	0.374		106682	106692	106662	D
A	2	41.1-109.9	1.62-4.33	7.0	0.276				92172	D
B	3 inline	19.0-57.1	0.75-2.25	9.5	0.374				107552	D
C	3PCD	27.9-104.1	1.01-4.01	9.5	0.374		107662		107592	D

## Output spindles for use with multiple spindle heads (2)

MAXIMUM COLLET SIZE	AFD205 AFD215 AFDE200/230	AFD415 AFDE400/430 AFDE410/440	AFDE610/640 AFD625
PART NO.	PART NO.	PART NO.	PART NO.
K35	B24	B24	B24

### (2) How to order

Examples:

AFDE200-2850-A1-K32 + 174183

AFD415-3400-A6-B24 + 107552

AFDE610-900-A1-B24 + 106672

## Multiple Spindle Heads

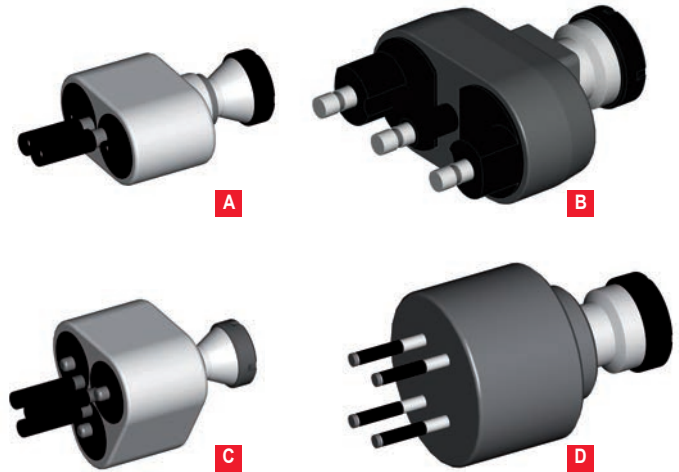
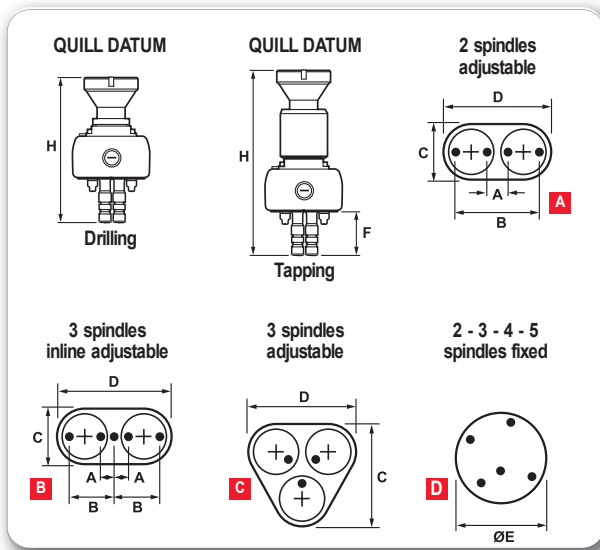

TYPE OF HEAD	PART NO.	MAX. SPEED	MIN./MAX. CENTRES A - B		MIN. PCD		MAX. PCD		DIMENSIONS							
			mm	in.	mm	in.	mm	in.	C	D	F	H				
		rpm	mm	in.	mm	in.	mm	in.	mm	in.	mm	in.	mm	in.		
<b>ADJUSTABLE SPINDLE</b>																
A	92142	5300	9.5-54.0	0.37-2.13					50.8	2.00	83	2.27	50.8	2.00	175.4	6.91
A	92152	5300	12.7-64.0	0.50-2.52					50.8	2.00	83	2.27	50.8	2.00	175.4	6.91
A	92172	8500	41.1-109.9	1.62-4.33					62.0	2.44	137	5.39	60.0	2.36	196	7.72
A	92222	1400	12.7-64.0	0.50-2.52					50.8	2.00	83	3.27	50.8	2.00	233.8	9.20
A	106662	5300	19.0-95.0	0.75-3.74					76.0	2.99	124	4.88	68.3	2.69	212	8.35
A	106672	5300	19.0-95.0	0.75-3.74					76.0	2.99	124	4.88	68.3	2.69	211	8.31
A	106682	1500	19.0-95.0	0.75-3.74					76.0	2.99	124	4.88	68.3	2.69	261.5	10.30
A	106692	1500	19.0-95.0	0.75-3.74					76.0	2.99	124	4.88	68.3	2.69	260	10.24
B	107552	5300	19.0-57.1	0.75-2.25					99.2	3.90	142.9	5.63	68.3	2.69	212.3	8.36
B	107562	5300	19.0-27.1	0.75-2.25					99.2	3.90	142.9	5.63	68.3	2.69	188	7.40
C	107592	5300			27.9	1.01	104.1	4.01	120.3	4.74	132.6	5.22	68.3	2.69	211.2	6.31
A	107662	900			27.9	1.01	104.1	4.01	120.3	4.74	132.6	5.22	68.3	2.69	261.5	10.30
A	107672	900			27.9	1.01	104.1	4.01	120.3	4.74	132.6	5.22	68.3	2.69	260	10.24
	174183	5300	9.5-54.0	0.37-2.13					50.8	2.00	83	2.27	50.8	2.00	169.5	6.67
	204173	700	12.7-6	0.50-2.52					50.8	2.00	83	2.27	50.8	2.00	206.1	8.11

For fixed "D" spindle heads, please contact your local customer center.

Minimum centres are dependent on collet size, overall diameter on the distance between spindle and overall lengths on collet size.

Desoutter can provide dimensions if required.

Always provide details of hole pattern, hole diameters and material to be machined when ordering a fixed spindle head.

# Collets

## Collets for multiple spindle heads Type A - Threaded types



SIZE Ø		PART NO.	SIZE Ø		PART NO.
mm	in.		mm	in.	
1.0	0.039	60002	2.5	0.098	60172
1.1	0.043	60022	2.6	0.102	60182
1.2	0.047	60032	2.7	0.106	60192
1.3	0.051	60042	2.8	0.110	60202
1.4	0.055	60052	2.9	0.114	60222
1.5	0.059	60062	3.0	0.118	60232
1.6	0.063	60072	3.1	0.122	60242
1.7	0.067	60082	3.2	0.126	60252
1.8	0.071	60092	3.3	0.130	60262
1.9	0.075	60102	3.4	0.134	60272
2.0	0.079	60122	3.5	0.138	60282
2.1	0.083	60132	3.6	0.142	60292
2.2	0.087	60142	3.7	0.146	60302
2.3	0.091	60152	3.8	0.150	60322
2.4	0.094	60162	3.9	0.154	60332
			4.0	0.157	60342

## Collets for multiple spindle heads Type D - Threaded types



SIZE Ø		PART NO.	SIZE Ø		PART NO.
mm	in.		mm	in.	
2.0	0.079	39302	5.8	0.228	35242
2.1	0.083	39322	5.9	0.232	35252
2.2	0.087	39332	6.0	0.236	35272
2.3	0.091	39342	6.1	0.240	35282
2.4	0.094	39352	6.2	0.244	35292
2.5	0.098	39362	6.3	0.248	35302
2.6	0.102	39372	6.4	0.252	35332
2.7	0.106	39382	6.5	0.256	35342
2.8	0.110	39392	6.6	0.260	35352
2.9	0.114	39402	6.7	0.264	35362
3.0	0.118	39422	6.8	0.268	35382
3.1	0.122	39432	6.9	0.272	35392
3.2	0.126	34902	7.0	0.276	35402
3.3	0.130	34932	7.1	0.280	35422
3.4	0.134	34942	7.2	0.283	35432
3.5	0.138	34952	7.3	0.287	35452
3.6	0.142	34962	7.4	0.291	35462
3.7	0.146	34982	7.5	0.295	35472
3.8	0.150	34992	7.6	0.299	35492
3.9	0.154	35002	7.7	0.303	35502
4.0	0.157	35022	7.8	0.307	35522
4.1	0.161	35032	7.9	0.311	35532
4.2	0.165	35042	8.0	0.315	35552
4.3	0.169	35052	8.1	0.319	35562
4.4	0.173	35062	8.2	0.323	35572
4.5	0.177	35072	8.3	0.327	35582
4.6	0.181	35082	8.4	0.331	35592
4.7	0.185	35092	8.5	0.335	36602
4.8	0.189	35102	8.6	0.339	35622
4.9	0.193	35122	8.7	0.342	35632
5.0	0.197	35132	8.8	0.346	35652
5.1	0.201	35152	8.9	0.350	35672
5.2	0.205	35172	9.0	0.354	35682
5.3	0.209	35182	9.1	0.358	35692
5.4	0.213	35192	9.2	0.362	35722
5.5	0.217	35202	9.3	0.366	35732
5.6	0.220	35222	9.4	0.370	35752
5.7	0.224	35232	9.5	0.374	35762

## Collets for multiple spindle heads Type B - Threaded types



SIZE Ø		PART NO.	SIZE Ø		PART NO.
mm	in.		mm	in.	
1.0	0.039	39442	3.8	0.150	28092
1.1	0.043	39452	3.9	0.154	28102
1.2	0.047	39462	4.0	0.157	28122
1.3	0.051	39472	4.1	0.161	28132
1.4	0.055	39482	4.2	0.165	28142
1.5	0.059	39492	4.3	0.169	28152
1.6	0.063	27852	4.4	0.173	28162
1.7	0.067	39502	4.5	0.177	28172
1.8	0.071	27862	4.6	0.181	28182
1.9	0.075	39522	4.7	0.185	28192
2.0	0.079	27872	4.8	0.189	28202
2.1	0.083	27882	4.9	0.193	28222
2.2	0.087	27892	5.0	0.197	28232
2.3	0.091	27902	5.1	0.201	28252
2.4	0.094	27922	5.2	0.205	28272
2.5	0.098	27932	5.3	0.209	28282
2.6	0.102	27942	5.4	0.213	28292
2.7	0.106	27952	5.5	0.217	28302
2.8	0.110	27962	5.6	0.220	28322
2.9	0.114	27972	5.7	0.224	28332
3.0	0.118	27982	5.8	0.228	28342
3.1	0.122	27992	5.9	0.232	28352
3.2	0.126	28002	6.0	0.236	28372
3.3	0.130	28032	6.1	0.240	28382
3.4	0.134	28042	6.2	0.244	28392
3.5	0.138	28052	6.3	0.248	28402
3.6	0.142	28062	6.4	0.252	39532
3.7	0.146	28082	6.5	0.256	39542

## Collets for multi spindle heads Type C For use with B2 (326573), R2 (384113), K2 (357183), K42 (375263)



SIZE Ø		PART NO.	SIZE Ø		PART NO.
mm	in.		mm	in.	
0.5-1.0	0.020-0.039	52582	3.1-4.0	0.122-0.157	52642
1.1-1.5	0.043-0.059	52592	4.1-5.0	0.161-0.197	52652
1.6-2.0	0.063-0.079	52602	5.1-6.0	0.201-0.234	52662
2.1-2.5	0.083-0.098	52622	6.1-7.0	0.240-0.276	52672
2.6-3.0	0.102-0.118	2632			

## For use with R36 (389273), ER25 TYPE



SIZE Ø		PART NO.	SIZE Ø		PART NO.
mm	in.		mm	in.	
6.0-7.0	0.236-0.276	104942	11.1-12.0	0.437-0.472	104992
7.1-8.0	0.279-0.315	104952	12.1-13.0	0.476-0.512	105002
8.1-9.0	0.319-0.354	104962	13.1-14.0	0.516-0.551	105022
9.1-10.0	0.358-0.394	104972	14.1-15.0	0.555-0.591	105032
10.1-11.0	0.397-0.433	104982	15.1-16.0	0.594-0.630	105042

## AFDE200/230 - AFD205/215

### Parallel Clamp

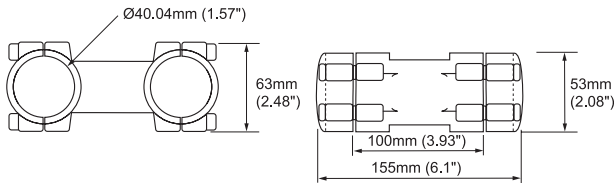

### Swan Neck Clamp

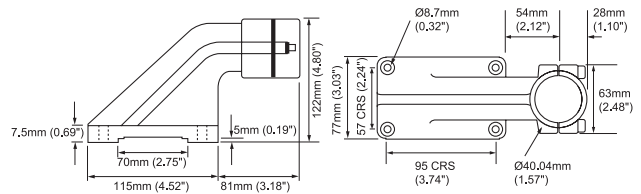

### Right Angle Clamp

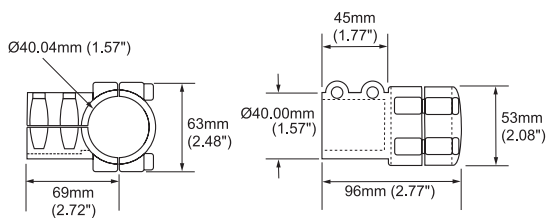

### Base Clamp

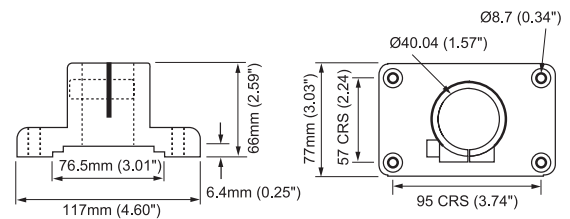

### Swivel Clamp

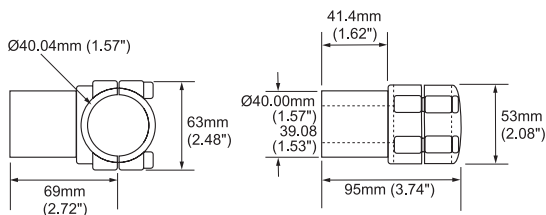

### Bar Clamp

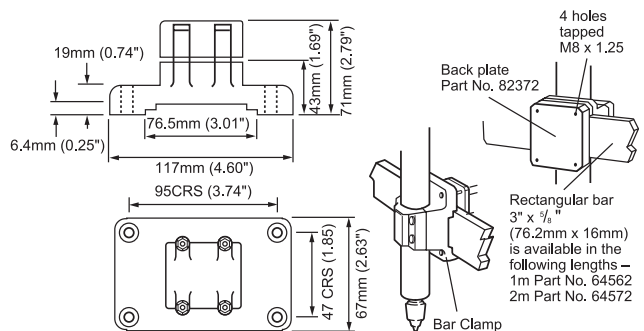

### Mounting Tube

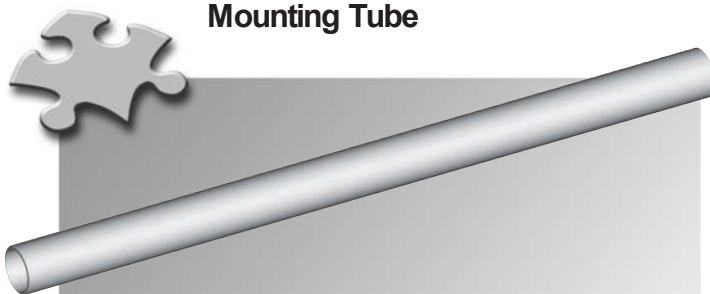

Tubing is of the same outside diameter as the auto feed unit and is available in the following standard lengths.

## AFDE200/230 - AFD205/215

### ACCESSORIES

	PART NO.
• Parallel clamp	61832
• Right Angle clamp	61822
• Swivel clamp	61802
• Swan Neck clamp	61862
• Base clamp	61842
• Bar clamp	61852
• Mounting Tube 228 (9") length, $\text{Ø}$ 39.97-40 (1.574"-1.575")	39702
• Mounting Tube 457 (18") length, $\text{Ø}$ 39.97-40 (1.574"-1.575")	39732
• Mounting Tube 610 (24") length, $\text{Ø}$ 39.97-40 (1.574"-1.575")	39742

# Clamps

## AFDE400/430/410/440 - AFD415

### Parallel Clamp

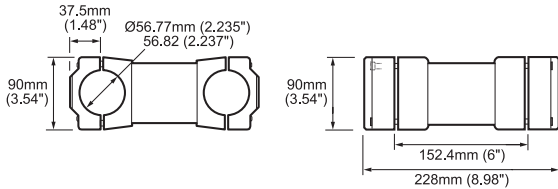

### Adjustable Bar Clamp

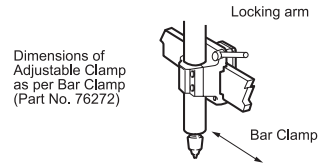

### Right Angle Clamp

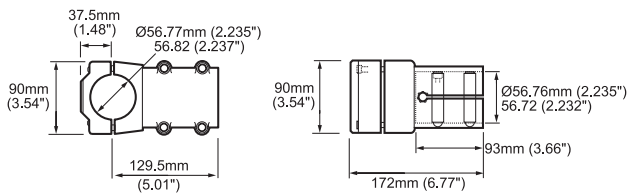

### Narrow Bar Clamp

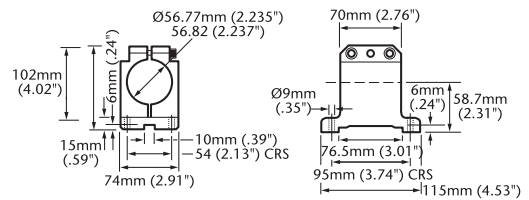

### Swivel Clamp

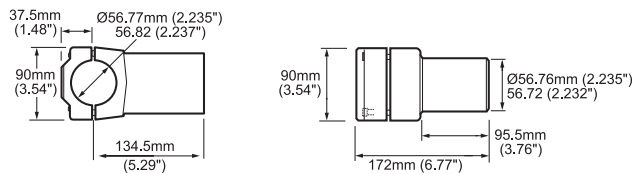

### Bar Clamp

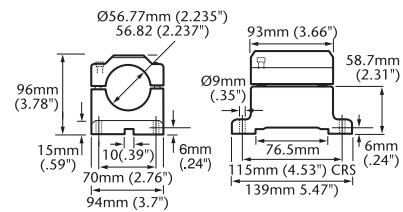

### Base Clamp

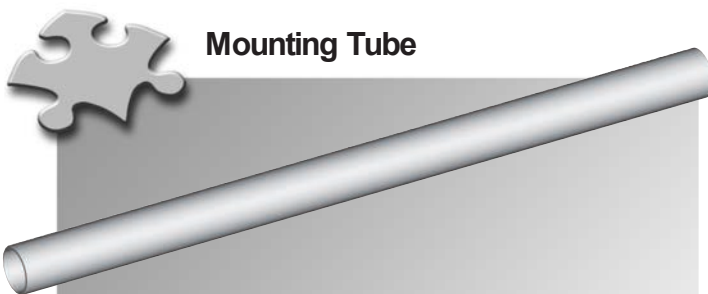
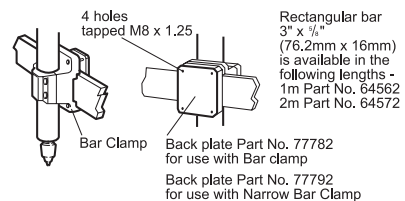
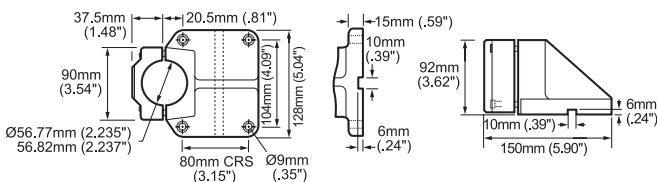

### Mounting Tube

Tubing is of the same outside diameter as the auto feed unit and is available in the following standard lengths.

## AFDE400/430/410/430 - AFD415

### ACCESSORIES

	PART NO.
• Parallel clamp	76352
• Right Angle clamp	76342
• Swivel clamp	76332
• Bar clamp	76272
• Base clamp	76302
• Adjustable bar Clamp	97042
• Narrow bar Clamp	76292
• Mounting Tube 305 (12 length, Ø 56.5-56.71 (2.225"-2.233"))	9462
• Mounting Tube 457 (18") length, Ø 56.5-56.71 (2.225"-2.233")	9472
• Mounting Tube 610 (24") length, Ø 56.5-56.71 (2.225"-2.233")	9482
• Mounting Tube 760 (30") length, Ø 56.5-56.71 (2.225"-2.233")	9492

## AFDE610/640 - AFD684

### Base Clamp

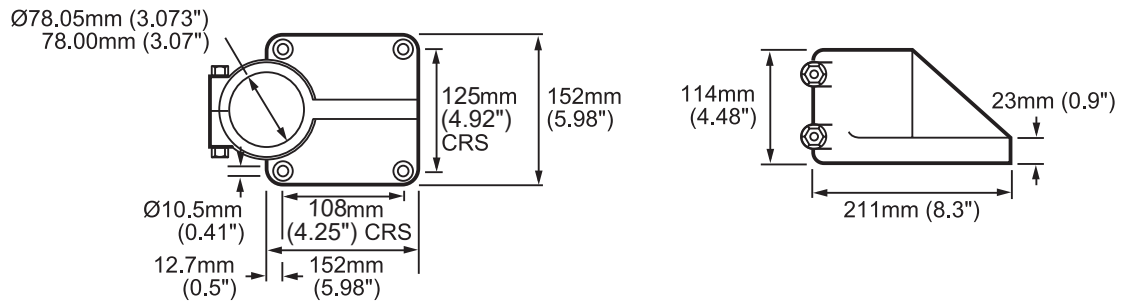

### Bar Clamp

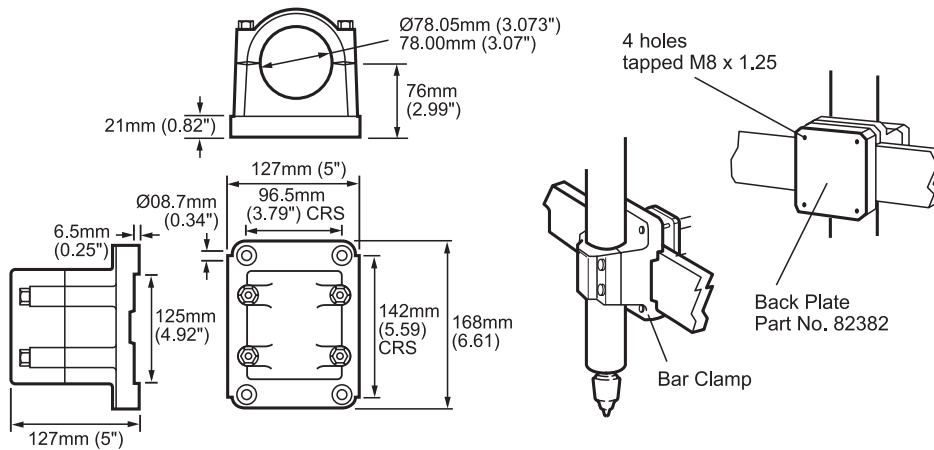

### Mounting Tube

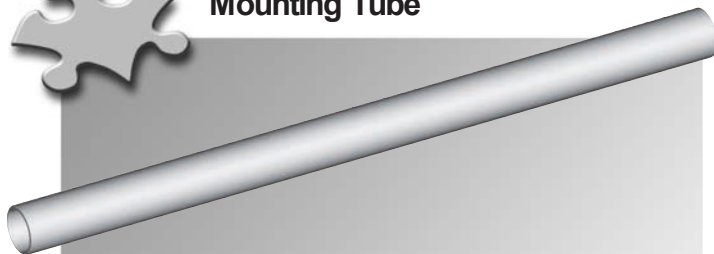

Tubing is of the same outside diameter as the auto feed unit and is available in the following standard lengths.

### AFDE610/640 - AFD625

#### ACCESSORIES

#### PART NO.

• Base clamp	32542
• Bar clamp	32532
• Mounting Tube 610 (24") length, Ø 78 (3.069")	32562
• Mounting Tube 915 (36") length, Ø 78 (3.069")	32572

# Clamps

## AFTE480

### Parallel Clamp

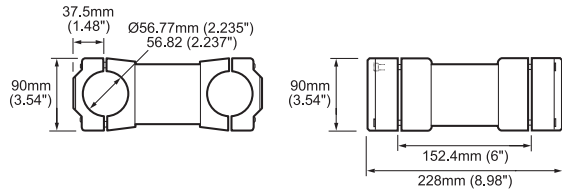

### Narrow Bar Clamp

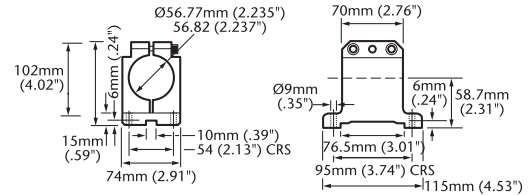

### Right Angle Clamp

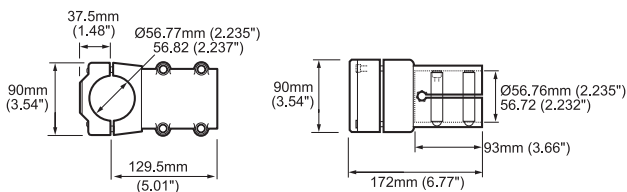

### Base Clamp

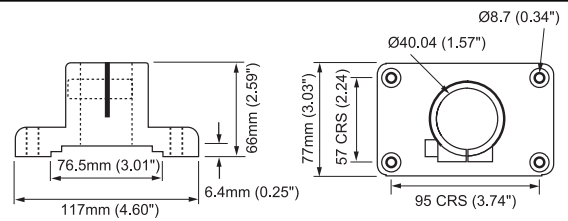

### Swivel Clamp

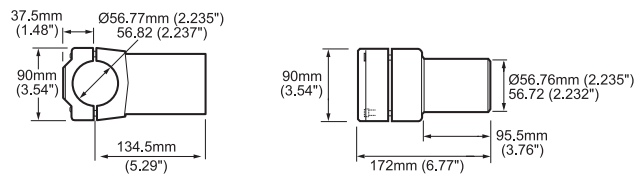

### Bar Clamp

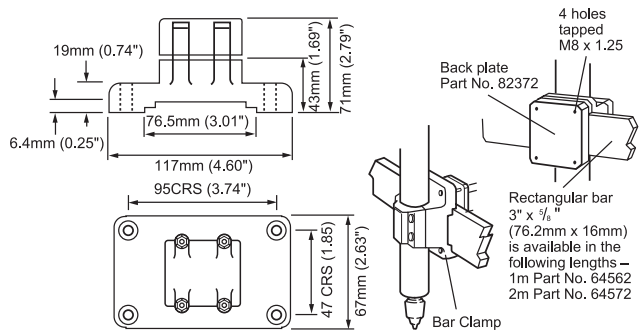

### Base Clamp

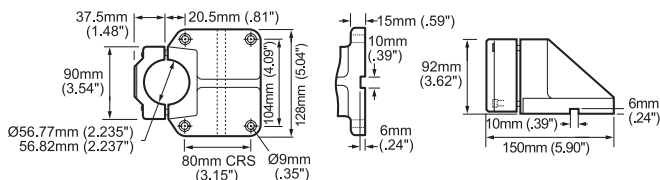

### Adjustable Bar Clamp

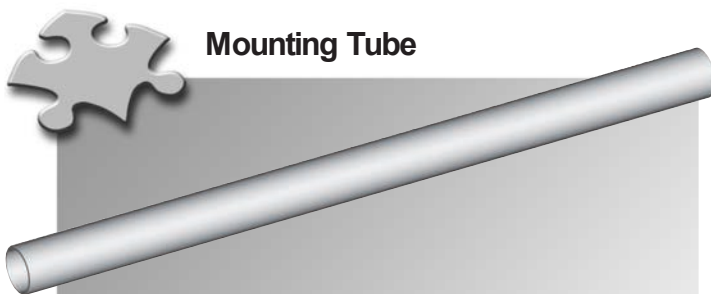
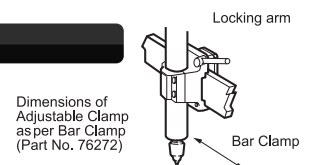

### Mounting Tube

Tubing is of the same outside diameter as the auto feed unit and is available in the following standard lengths.

## AFTE480

### ACCESSORIES

	PART NO.
• Parallel clamp	76352
• Right Angle clamp	76342
• Swivel clamp	76332
• Bar clamp	76272
• Base clamp	76302
• Adjustable bar Clamp	97042
• Narrow bar Clamp	76292
• Mounting Tube 305 (12 length, Ø 56.5-56.71 (2.225"-2.233"))	9462
• Mounting Tube 457 (18" length, Ø 56.5-56.71 (2.225"-2.233"))	9472
• Mounting Tube 610 (24" length, Ø 56.5-56.71 (2.225"-2.233"))	9482
• Mounting Tube 760 (30" length, Ø 56.5-56.71 (2.225"-2.233"))	9492





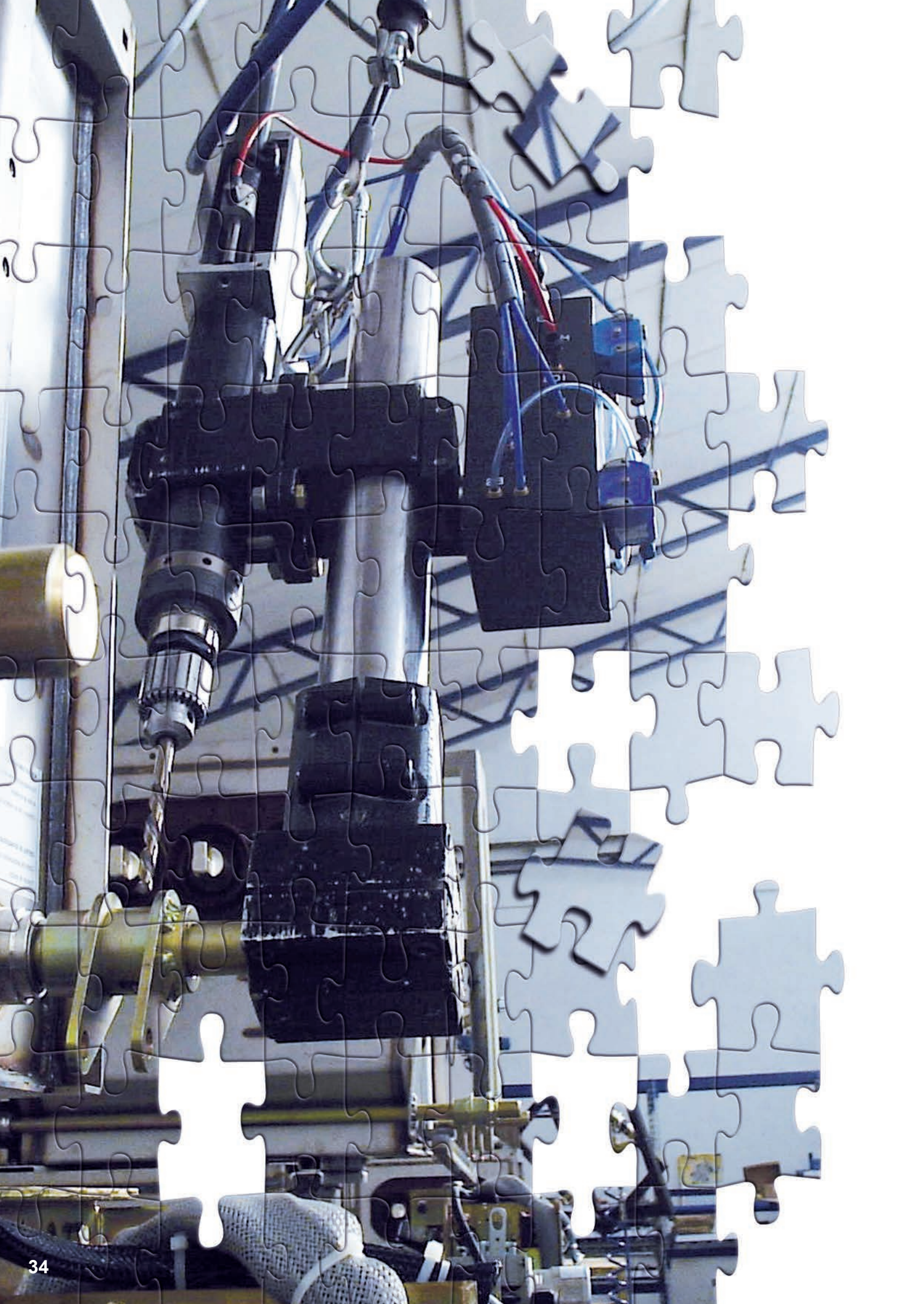

# AFD Selection Program

The Desoutter AFD selection program allows you to select Auto Feed Drills or Tappers for applications where the following parameters are available:

- Hole diameter or thread size
- Hole or thread depth
- Thread pitch (tapping only)
- Number of holes
- Material to be drilled or tapped
- Blind or through hole (tapping only)

For further details please contact your local Desoutter representative.

**AFD SELECTION TEMPLATE**



THIS TEMPLATE WILL HELP YOU TO FIND THE RECOMMENDED TOOL FOR YOUR DRILLING JOB  
Please be warned that its use for Reaming Job is not advised.

How to use :

- Section 1 - Please fill the mandatory fields marked with \* and, if available, other optional information
- Section 2 - Recommended tools will appear with additional information

---

Drill diameter \*

Number of spindles \*

MATERIAL SELECTION \*

Thickness \*

Pre-Drill diameter

Approach time

Retract time

Use of carbide drills bit?

---

**RECOMMENDED TOOL :**

Pneumatic tool :

Electropneumatic tool :

OPTION - In case you want to change the parameters for Material :

v<sub>c</sub> "Cutting speed" (m/min)    Feed Speed (mm/r)

Automatic Parameters :    

Customized Parameters \* :

\* If filled, they will replace the automatic parameters in the calculation

---

Technical Results - FOR INFORMATION

Recommended Speed	663 rpm
Dynamic thrust "T"	1305 N
Lost Power "P"	0,476 kW
Engine Power	0,560 kW
Speed feed "R"	143,2 mm/min
Drilling time	6,1 s
Cycle drilling time	6,4 s

(calculated for open hole)

HCU CHOICE - OPTIONAL

Open Hole - Max. Stroke =  -> D1 HCU Unit 91942 can be used

Blind Hole - Max. Stroke =  -> D1 HCU Unit 91942 can be used

PECK FEED - OPTIONAL

No need to add a Peck Feed Kit

Release date : 16/02/2016



CAD drawing files for the Desoutter Auto Feed Drills and Tappers are available on [www.desouttertools.com/resource-centre](http://www.desouttertools.com/resource-centre)



For more information about Desoutter tools, please ask for the Desoutter catalogue 6159939341 or visit [www.desouttertools.com](http://www.desouttertools.com) and look in the Industrial Tools on line catalogue

# More Than Productivity



[www.desouttertools.com](http://www.desouttertools.com)

English  
© Copyright 2016  
March 2016 - Issue 2